

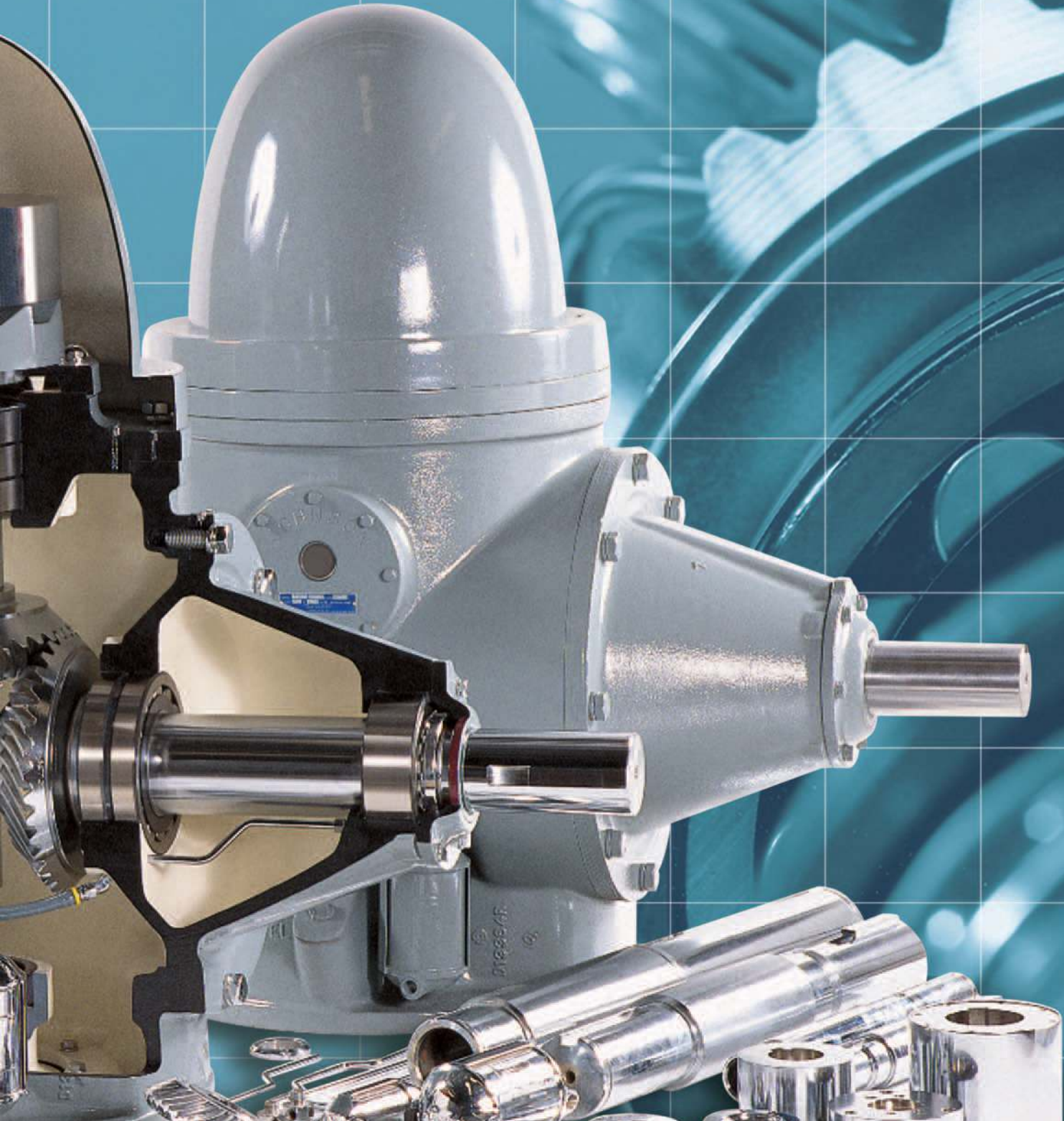

JOHNSON GEAR

Right Angle Gear Drive

**RIGHT ANGLE DRIVES FOR
IRRIGATION, INDUSTRIAL, MUNICIPAL
AND FIRE PROTECTION**



JOHNSON RIGHT ANGLE GEAR DRIVE

THESE FEATURES MEAN CONTINUOUS ON-STREAM PERFORMANCE,
LOW MAINTENANCE AND DEPENDABILITY

* **NON-REVERSE COUPLING**, with four pins, standard on hollow-shaft drives

* **RATCHET PLATE**, high strength ductile iron construction for longer lasting ramps.

THRUST BEARINGS angular-contact, and pressure lubricated

HOUSING High tensile strength cast gray iron Grade G3000

OIL SIGHT GLASS for quick visual inspection of gear lubrication (Not shown)

* **HOLLOW or SOLID SHAFT** made from 4140 steel

OIL COOLER externally mounted with top and bottom cooling water connections. Standard for all models H60 thru H1500

* **DOME**, weather proof and light weight with cap

SPIRAL BEVEL GEARS for quite, high torque operation

INNER BEARING, double spherical roller bearing

* **SPRAG NON-REVERSE** (optional)

DOUBLE LIP OIL SEAL

OUTER BEARING, angular contact, double row

PUMP BEARING, deep groove ball bearing, single row

PUMP RUNNER, positive displacement oil pump for pressure lubrication of bearings

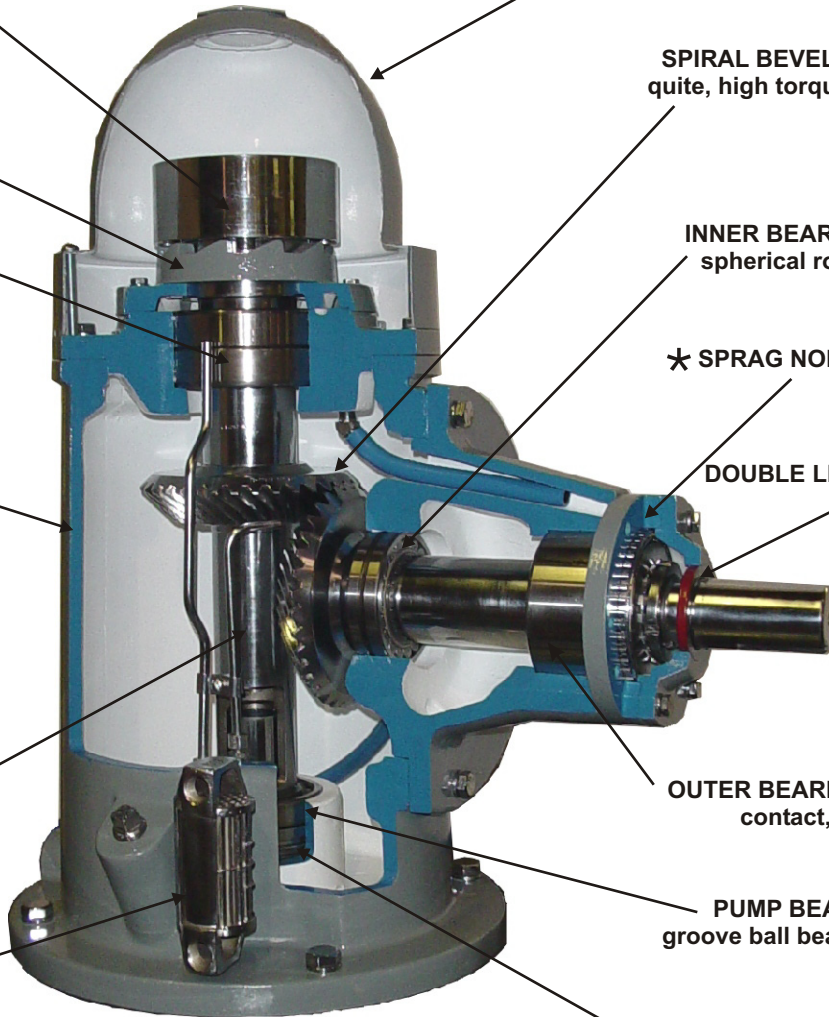

* marks a new or improved design



GET MORE DRIVE FOR YOUR PUMPING DOLLAR!

BENEFITS AND APPLICATIONS

The Johnson Right Angle Gear Drive provides positive power transmission from horizontal prime movers to vertical pump shafts. It offers economy, efficiency, space-saving, and the ability to function well under varying climatic conditions.

Johnson Right Angle Gear Drives (Factory Mutual Approved) are used in a variety of applications such as: irrigation; municipal water supply and sewage disposal; fire protection; flood protection; cooling towers; wind towers; and marine service.

A variety of models are available to meet specific requirements of high and low speed prime movers and pumps.

HORSEPOWER RATING

The Johnson Right Angle Gear Drive model number indicates the normal horsepower rating at 1760 RPM of the vertical pump shaft. The first number of each ratio relationship shown in Table 1 refers to the horizontal shaft speed. Horsepower and thrust capacities in Table 2 are based on vertical shaft speed and apply, regardless of gear ratios.

SERVICE FACTOR

Ratings in the catalog tables incorporate an adequate service factor for continuous duty when driving a centrifugal or turbine type deep well pump.

To select the correct size gear drives, use the tabulated values directly to match the horsepower required by the pump. On other applications consult factory.

The AGMA service factor for the spiral bevel gears is 1.5 or greater. Specific values for given applications are available on request.

Other items that influence the unit ratings are bearings, shafts, temperature, and lubrication. All were considered in compiling Table 2 on ratio selection. The recommendation is to stay within the tabulated ratings; consult the factory regarding any variations. Overloading will void warranty.

When oil cooler equipped drives are operated at rated capacity, coolant at about 70° F should be available for oil cooler use. Low thrust loads, slow speeds, good air circulation and intermittent operation also influence final selection.

ROTATION

The direction of rotation of the vertical shaft is as viewed from above and the rotation of the horizontal shaft is as if seen from the stub end. See drawings designated Figs. 1 through 4 on following pages.

Gear drives with special rotations (as designated in Figs. 2, 3 and 4) and gear drives with speed decreasing ratios of 7:4 or higher are manufactured to order. Such orders are not subject to cancellation without charge for parts processed.

TABLE 1.

Vert Shaft R.P.M.	Horizontal Shaft R.P.M.							
	Speed Increasing Ratios-Driver:Driven							
	1:2	4:7	2:3	3:4	4:5	5:6	10:11	1:1
580	290	331	387	435	464	483	527	580
720	360	411	480	540	576	600	655	720
860	430	491	573	645	688	717	782	860
1160	580	663	773	870	928	967	1055	1160
1460	730	834	973	1095	1168	1217	1327	1460
1760	880	1006	1173	1320	1408	1467	1600	1760
3460 *	1730	1977	2307	2595	2768	2883	3145	3460

Vert Shaft R.P.M.	Horizontal Shaft R.P.M.										
	Speed Decreasing Ratios-Driver:Driven										
	11:10	6:5	5:4	4:3	3:2	7:4	2:1	9:4	5:2	11:4	3:1
580	638	696	725	733	870	1015	1160	1305	1450	1595	1740
720	792	864	900	960	1080	1260	1440	1620	1800	1980	2160
860	946	1032	1075	1147	1290	1505	1720	1935	2150	2365	2580
1160	1276	1392	1450	1547	1740	2030	2320	2610	2900	3190	3480
1460	1606	1752	1825	1947	2190	2555	2920	3285	3560	--	--
1760	1936	2112	2200	2347	2640	3080	3520	--	--	--	--

* Consult factory

THRUST CAPACITY

HOLLOW SHAFT DRIVES

Large capacity thrust bearings are provided to handle a wide range of pump equipment and heads of water. In most instances, the natural thrust of the gears is used to reduce the load on the bearings. This condition necessitates a minimum downthrust requirement to prevent a bearing separation. Unless otherwise specified, Johnson Gear drive units are furnished with a thrust bearing arrangement DT. Ratings shown in the STANDARD column apply except for Model H750-H1500, which are designed with a spherical roller thrust bearing in order to accommodate large thrust capacities and to provide maximum up-thrust protection.

The TWO-WAY column shows the ratings for bearing arrangement DF. Upthrust and

downthrust can be accommodated with this configuration.

When the downthrust exceeds the values of the STANDARD column, select a suitable size from the HEAVY THRUST column. These ratings are for bearing arrangement DT/DT.

The heavy duty model can also be furnished with bearing arrangement of DF/DT. The downthrust ratings are taken from the STANDARD column. The upthrust ratings are taken from the TWO-WAY column.

OTHER DRIVES

Ratings for **Combination, Solid Shaft, and Redi-Torq®** drives are taken from the TWO-WAY column. Consult the factory when there are conditions not covered by the following table.

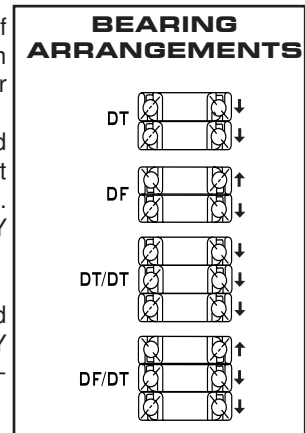

TABLE 2. THRUST CAPACITY (in pounds)

Model	Vertical Shaft RPM	H. P.	Standard		Heavy		Two-Way	Model	Vertical Shaft RPM	H. P.	Standard		Heavy		Two-Way
			Downthrust Only				Down or Up Thrust Max.				Downthrust Only				Down or Up Thrust Max.
			Min.	Max.	Min.	Max.					Min.	Max.	Min.	Max.	
H20	1160	15		1400	750	2300	1400	H250	720	125	3600	12650	3600	17500	7800
	1460	17		1300	750	2200	1300		860	145	3450	12000	3450	16700	7400
	1760	20		1200	750	2000	1200		1160	180	3200	11200	3200	15500	7000
	3460	30		1000	750	1600	1000		1460	215	3000	10600	3000	14600	6500
H40	1160	30		900	4400		2600	H300	720	150	3750	13700	3750	18800	8200
	1460	35		850	4200		2500		860	174	3550	13000	3600	17900	7800
	1760	40		800	4000		2400		1160	216	3350	12200	3350	16700	7300
H60	860	34	1450	6000			3600	H350	1460	258	3150	11500	3150	15700	6900
	1160	43	1300	5500			3300		1760	300	3000	11000	3000	15000	6600
	1460	52	1250	5200			3100		720	175	4250	16300	4200	20000	9800
	1760	60	1200	5000			3000		860	203	4050	15500	4000	19000	9300
H80	860	46	2050	7400	1500	9700	4400	H425	1160	252	3750	14400	3750	17800	8600
	1160	58	1950	6900	1500	9100	4100		1460	301	3550	13600	3500	16700	8200
	1460	69	1800	6400	1500	8300	3800		1760	350	3400	13000	3400	16000	7800
	1760	80	1700	6000	1500	8000	3000		720	213	4650	18700	4750	25000	11200
H110	860	63	2350	7400	1800	9700	4400	H500	860	246	4450	17900	4550	24000	10700
	1160	80	2200	6900	1800	9100	4100		1160	306	4150	16600	4200	22000	10000
	1460	95	2050	6400	1800	8500	3800		1460	366	3900	15700	4000	21000	9400
	1760	110	1900	6000	1800	8000	3000		1760	425	3800	15000	3800	20000	9000
H125	720	63	2900	8500	2800	12200	5100	H600	580	215	6048	21600	6048	28800	12900
	860	72	2700	8000	2650	11600	4800		690	240	5712	20400	5712	27200	12000
	1160	90	2550	7500	2500	10800	4500		720	250	5250	18700	5250	25000	11200
	1460	108	2400	7000	2300	10100	4200		860	290	5000	17900	5000	24000	10700
H150	1760	125	2200	6500	2200	9500	3900	1160	360	4650	16600	4600	22000	10000	
	720	75	3050	9800	3150	15000	5900	1460	430	4400	15700	4400	21000	9400	
	860	87	2950	9400	3000	14300	5600	1760	500	4200	15000	4200	20000	9000	
	1160	108	2750	8800	2800	13300	5300	580	258	6336	23000	6336	36000	13800	
H200	1460	129	2600	8300	2600	12500	5000	690	288	5900	21700	5900	34000	13000	
	1760	150	2500	8000	2500	12000	4800	720	300	5500	20000	5500	33500	12000	
	720	100	3600	12000	3400	16200	6750	860	348	5200	19000	5200	31500	11400	
	860	116	3300	11000	3200	15300	6300	1160	432	4900	17800	4900	28700	10700	
H250	1160	144	3050	10200	3000	14300	5700	1460	516	4600	16700	4600	26500	10000	
	1460	172	2850	9500	2850	13500	5300	1760	600	4400	16000	4400	25000	9600	
	1760	200	2700	9000	2700	13000	5100								

Ratings shown are for Fig. 1, rotation only. Consult factory for other figure ratings.

Model	Vertical Shaft RPM	H. P.	max down thrust	Model	Vertical Shaft RPM	H. P.	max down thrust	Model	Vertical Shaft RPM	H. P.	max down thrust	Model	Vertical Shaft RPM	H. P.	max down thrust
H750	580	322	47520	H1000	580	430	47520	H1200	580	516	57600	H1500	580	645	57600
	690	360	44880		690	480	44880		690	576	54400		690	720	54400
	720	375	44220		720	500	44220		720	600	53600		720	750	53600
	860	435	41580		860	580	41580		860	696	50400		860	870	50400
	1160	540	37950		1160	720	37950		1160	864	46000		1160	1080	46000
	1460	645	34980		1460	860	34980		1460	1032	42400		1460	1290	42400
1760	750	33000	1760	1000	33000	1760	1200	40000	1760	1500	40000				

TABLE 3. HORSEPOWER AND THRUST BEARING RATINGS

Vertical Shaft RPM	580	690	720	860	960	1160	1460	1760	2000	2200	2400*	2800*	3000*	3520*
% of HP at 1760 RPM	43	48	50	58	63	72	86	100	105	111	116	128	133	150
% of Thrust of 1760 RPM	144	136	134	126	122	115	106	100	96	92	90	85	83	79

*Consult factory when vertical shaft speed exceeds 2200 RPM.

HOLLOW SHAFT DRIVE

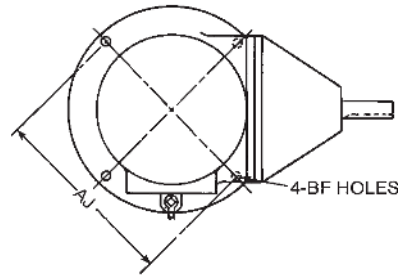
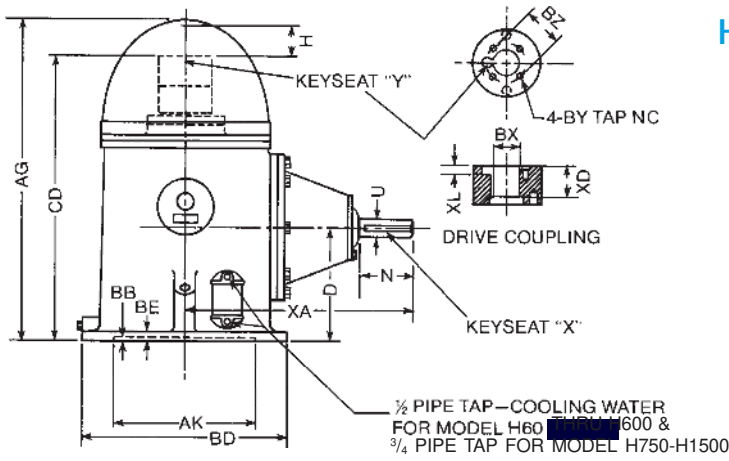

U-XA-N and X dimensions for all speed decreasing ratios in Models H150 and up are subject to change. See Table 8 on page 7. CD and H dimensions for all heavy thrust drives are subject to change. See Table 6 at bottom of page.

TABLE 4. DIMENSIONS (in inches)

Model	CD	D	U	XA	N	AG	H	BE	BD	AJ	AK	BB	BF	Keyseat X	Max Bx		XD
															Fig. 1, 4	Fig. 2, 3	
H20	14 ¹ / ₂	6 ³ / ₈	1 ¹ / ₈	13	2 ³ / ₄	18	3	5 ⁵ / ₈	10	9 ¹ / ₈	8 ¹ / ₄	3 ³ / ₁₆	7 ⁷ / ₁₆	1 ¹ / ₄ X 1 ¹ / ₈ X 2 ¹ / ₄	1	NA	1 ¹ / ₄
H40 (12)	20 ¹ / ₄	9	1-7/8	16	3 ¹ / ₂	24 ³ / ₄	4	3 ³ / ₄	12	9 ¹ / ₈	8 ¹ / ₄	3 ³ / ₁₆	7 ⁷ / ₁₆	3 ³ / ₈ X 3 ³ / ₁₆ X 2 ³ / ₄	1 ¹ / ₂	1 ¹ / ₄	1 ³ / ₄
H40	20 ¹ / ₄	9	1-7/8	16	3 ¹ / ₂	24 ³ / ₄	4	3 ³ / ₄	16 ¹ / ₂	14 ³ / ₄	13 ¹ / ₂	3 ³ / ₁₆	1 ¹ / ₁₆	3 ³ / ₈ X 3 ³ / ₁₆ X 2 ³ / ₄	1 ¹ / ₂	1 ¹ / ₄	1 ³ / ₄
H60	20 ¹ / ₄	9	1-7/8	16	3 ¹ / ₂	24 ³ / ₄	4	3 ³ / ₄	16 ¹ / ₂	14 ³ / ₄	13 ¹ / ₂	3 ³ / ₁₆	1 ¹ / ₁₆	3 ³ / ₈ X 3 ³ / ₁₆ X 2 ³ / ₄	1 ¹ / ₂	1 ¹ / ₄	1 ³ / ₄
H80	20 ¹ / ₄	9	1-7/8	16 ¹ / ₂	3 ¹ / ₂	24 ³ / ₄	4	3 ³ / ₄	16 ¹ / ₂	14 ³ / ₄	13 ¹ / ₂	3 ³ / ₁₆	1 ¹ / ₁₆	3 ³ / ₈ X 3 ³ / ₁₆ X 2-3/4	1 ¹ / ₂	NA	1 ³ / ₄
H110	25	11 ³ / ₈	2	17 ¹ / ₂	3 ¹ / ₂	29 ¹ / ₂	4	1	16 ¹ / ₂	14 ³ / ₄	13 ¹ / ₂	3 ³ / ₁₆	1 ¹ / ₁₆	1 ¹ / ₂ X 1 ¹ / ₄ X 2 ³ / ₄	1 ¹ / ₂	1 ¹ / ₂	2 ¹ / ₈
H125	25	11 ³ / ₈	2	17 ¹ / ₂	3 ¹ / ₂	29 ¹ / ₂	4	1	16 ¹ / ₂	14 ³ / ₄	13 ¹ / ₂	3 ³ / ₁₆	1 ¹ / ₁₆	1 ¹ / ₂ X 1 ¹ / ₄ X 2 ³ / ₄	1 ¹ / ₂	1 ¹ / ₂	2 ¹ / ₈
H150	30	13 ¹ / ₄	2 ⁷ / ₁₆	20 ¹ / ₂	4 ³ / ₄	34 ¹ / ₂	4	1	20	14 ³ / ₄	13 ¹ / ₂	3 ³ / ₁₆	1 ¹ / ₁₆	5 ⁵ / ₈ X 5 ⁵ / ₁₆ X 3 ³ / ₄	1 ¹⁵ / ₁₆	1 ³ / ₄	2 ³ / ₈
H200	30	13 ¹ / ₄	2 ⁷ / ₁₆	20 ¹ / ₂	4 ³ / ₄	34 ¹ / ₂	4	1	20	14 ³ / ₄	13 ¹ / ₂	3 ³ / ₁₆	1 ¹ / ₁₆	5 ⁵ / ₈ X 5 ⁵ / ₁₆ X 3 ³ / ₄	1 ¹⁵ / ₁₆	1 ³ / ₄	2 ³ / ₈
H250	34 ¹ / ₄	15	2 ³ / ₄	24	5 ¹ / ₂	40	5 ¹ / ₄	1 ¹ / ₈	20	14 ³ / ₄	13 ¹ / ₂	3 ³ / ₁₆	1 ¹ / ₁₆	5 ⁵ / ₈ X 5 ⁵ / ₁₆ X 4 ³ / ₄	2	2	2 ⁵ / ₈
H300	34 ¹ / ₄	15	2 ³ / ₄	24	5 ¹ / ₂	40	5 ¹ / ₄	1 ¹ / ₈	20	14 ³ / ₄	13 ¹ / ₂	3 ³ / ₁₆	1 ¹ / ₁₆	5 ⁵ / ₈ X 5 ⁵ / ₁₆ X 4 ³ / ₄	2	2	2 ⁵ / ₈
H350	38 ¹ / ₂	16 ¹ / ₂	2 ³ / ₄	29	5 ¹ / ₂	46	7	1 ¹ / ₄	24 ¹ / ₂	22*	13 ¹ / ₂	3 ³ / ₈	1 ⁵ / ₁₆	5 ⁵ / ₈ X 5 ⁵ / ₁₆ X 4 ³ / ₄	2 ³ / ₁₆	2 ³ / ₁₆	3
H425	39 ¹ / ₂	16 ¹ / ₂	3	30	5 ³ / ₄	46	6 ¹ / ₄	1 ¹ / ₄	24 ¹ / ₂	22*	13 ¹ / ₂	3 ³ / ₈	1 ⁵ / ₁₆	3 ³ / ₄ X 3 ³ / ₈ X 4 ³ / ₄	2 ⁷ / ₁₆	2 ⁷ / ₁₆	3 ³ / ₈
H500	39 ¹ / ₂	16 ¹ / ₂	3 ¹ / ₂	31	6 ³ / ₄	46	6 ¹ / ₄	1 ¹ / ₄	24 ¹ / ₂	22*	13 ¹ / ₂	3 ³ / ₈	1 ⁵ / ₁₆	7 ⁷ / ₈ X 7 ⁷ / ₁₆ X 5 ¹ / ₂	2 ⁷ / ₁₆	2 ⁷ / ₁₆	3 ³ / ₈
H600	42 ¹ / ₂	16 ¹ / ₂	3 ³ / ₄	33	7 ¹ / ₂	51	8	1 ¹ / ₄	24 ¹ / ₂	22*	13 ¹ / ₂	3 ³ / ₈	1 ⁵ / ₁₆	7 ⁷ / ₈ X 7 ⁷ / ₁₆ X 5 ¹ / ₂	2 ¹¹ / ₁₆	2 ¹¹ / ₁₆	4
H750	45	20 ¹ / ₂	3 ³ / ₄	33	7 ³ / ₄	54	7	1 ¹ / ₄	24 ¹ / ₂	22*	13 ¹ / ₂	3 ³ / ₈	1 ⁵ / ₁₆	7 ⁷ / ₈ X 7 ⁷ / ₁₆ X 6 ¹ / ₄	3 ³ / ₁₆	3 ³ / ₁₆	4
H1000	45	20 ¹ / ₂	3 ³ / ₄	33	7 ³ / ₄	54	7	1 ¹ / ₄	24 ¹ / ₂	22*	13 ¹ / ₂	3 ³ / ₈	1 ⁵ / ₁₆	7 ⁷ / ₈ X 7 ⁷ / ₁₆ X 6 ¹ / ₄	3 ³ / ₁₆	3 ³ / ₁₆	4
H1200	45 ³ / ₄	19	4	36	7 ¹ / ₂	54	7 ⁵ / ₈	1 ¹ / ₂	30 ¹ / ₂	26*	22	3 ³ / ₈	1 ⁵ / ₁₆	1 X 1 ¹ / ₂ X 7	3 ³ / ₁₆	3 ³ / ₁₆	4
H1500	45 ³ / ₄	19	4	36	7 ¹ / ₂	54	7 ⁵ / ₈	1 ¹ / ₂	30 ¹ / ₂	26*	22	3 ³ / ₈	1 ⁵ / ₁₆	1 X 1 ¹ / ₂ X 7	3 ³ / ₁₆	3 ³ / ₁₆	4

*Also 5/8-11 Tap on 14-3/4 Bolt Circle 1" Deep
NA - Not Available

TABLE 5. STANDARD DRIVE COUPLING DIMENSIONS

BX Bore	BZ Bolt Circle	BY Tap	XL Depth	Y Keyseat
3/4	1 ³ / ₈	10-32	5 ¹ / ₁₆	3 ³ / ₁₆ X 3 ³ / ₃₂
1	1 ³ / ₈	10-32	7 ¹ / ₁₆	1 ¹ / ₄ X 1 ¹ / ₈
1 ³ / ₁₆	1 ³ / ₄	1 ¹ / ₄ -20	7 ¹ / ₁₆	1 ¹ / ₄ X 1 ¹ / ₈
1 ¹ / ₄	1 ³ / ₄	1 ¹ / ₄ -20	9 ¹ / ₁₆	1 ¹ / ₄ X 1 ¹ / ₈
1 ⁷ / ₁₆	2 ¹ / ₈	1 ¹ / ₄ -20	9 ¹ / ₁₆	3 ³ / ₈ X 3 ³ / ₁₆
1 ¹ / ₂	2 ¹ / ₈	1 ¹ / ₄ -20	9 ¹ / ₁₆	3 ³ / ₈ X 3 ³ / ₁₆
1 ¹¹ / ₁₆	2 ¹ / ₂	1 ¹ / ₄ -20	9 ¹ / ₁₆	3 ³ / ₈ X 3 ³ / ₁₆
1 ¹⁵ / ₁₆	2 ¹ / ₂	1 ¹ / ₄ -20	11 ¹ / ₁₆	1 ¹ / ₂ X 1 ¹ / ₄
2 ³ / ₁₆	3 ¹ / ₄	3 ³ / ₈ -16	11 ¹ / ₁₆	1 ¹ / ₂ X 1 ¹ / ₄
2 ⁷ / ₁₆	3 ¹ / ₄	3 ³ / ₈ -16	11 ¹ / ₁₆	5 ⁵ / ₈ X 5 ⁵ / ₁₆
2 ¹¹ / ₁₆	3 ³ / ₄	3 ³ / ₈ -16	11 ¹ / ₁₆	5 ⁵ / ₈ X 5 ⁵ / ₁₆
2 ¹⁵ / ₁₆	4 ¹ / ₄	3 ³ / ₈ -16	15 ¹ / ₁₆	3 ³ / ₄ X 3 ³ / ₈

TABLE 6. STANDARD DRIVE HEAVY THRUST DIMENSIONS

Model	CD	H
H80HT	21 ¹ / ₂	2 ³ / ₄
H110HT	26 ¹ / ₄	2 ³ / ₄
H125HT	26 ¹ / ₂	2 ¹ / ₂
H150HT	31 ¹ / ₄	2 ³ / ₄
H200HT	31 ¹ / ₄	2 ³ / ₄
H250HT	36	3 ¹ / ₂
H300HT	36	3 ¹ / ₂
H350HT	40 ¹ / ₄	5 ¹ / ₄
H425HT	39 ¹ / ₂	6 ¹ / ₄
H500HT	42	3 ³ / ₄
H600HT	42 ¹ / ₂	8

ROTATION

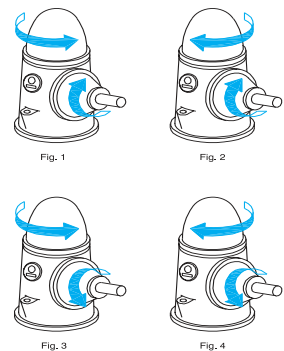

ROTATION DIAGRAM

Gear drives with special rotations (Figs. 2, 3, and 4) and gear drives with speed decreasing ratios of 7:4 or higher are manufactured to order, and such orders are not subject to cancellation without charge for parts processed.

SEE PAGES 10 & 11 FOR SOLID SHAFT DRIVES

SPRAG NON-REVERSE CLUTCH

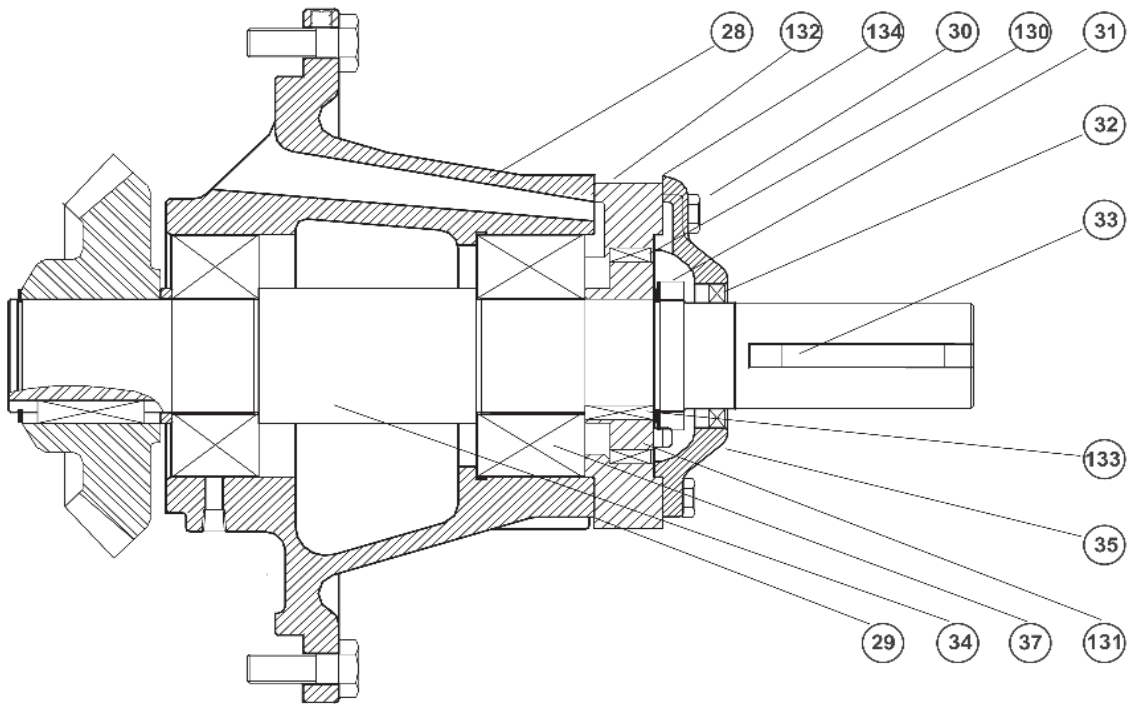

SPRAG NON-REVERSE

No.	Part Name	No.	Part Name
28	Horizontal Housing	35	Horizontal Housing Cover
29	Gasket-Outer race	37	Outer Bearing
30	Capscrew-Horiz. Hsg. Cover	130	Sprag Clutch
31	Locknut & Washer	131	Inner Race
32	Oil Seal	132	Outer Race
33	Key	133	Key
34	Drive Shaft	134	Gasket-Horz. Hsg. Cover

Provides Extra Non-Reverse Protection

We would like to introduce our version of the sprag non-reverse clutch. This device works as an instant lock and is mounted on the horizontal input shaft of the gear drive. It is fashioned from an industrial automotive transmission. The sprag is mounted between an inner and outer race, which are case hardened, made from 8620 alloy steel, and precision ground to size to insure long life. We believe our design to be superior due to the fact that the mating parts are register fit to allow exact alignment at all times. This design allows replacement in the field without alignment tools saving valuable time.

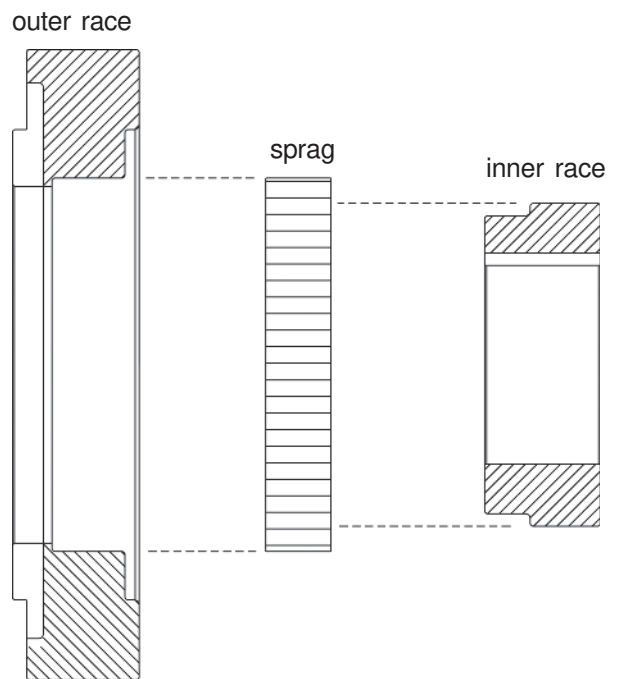

SPRAG NON-REVERSE HOLLOW SHAFT

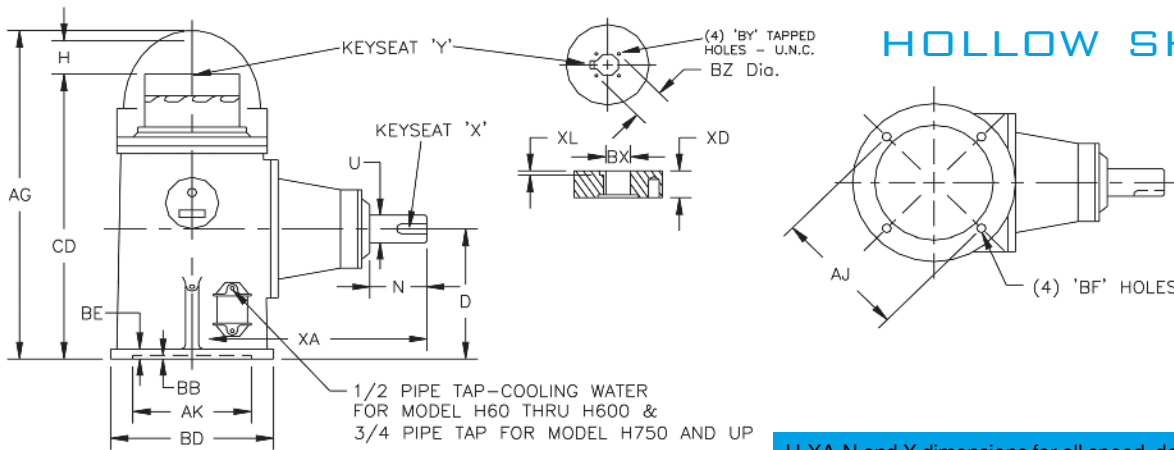

U-XA-N and X dimensions for all speed decreasing ratios in Models H150 and up are subject to change. See Table 8 at bottom of page. CD and H dimensions for all heavy thrust drives are subject to change. See Table 6 on page 5.

TABLE 7. DIMENSIONS (in inches)

Model	CD	D	U	XA	N	AG	H	BE	BD	AJ	AK	BB	BF	Keyseat X	Max Bx		XD
															Fig. 1, 4	Fig. 2, 3	
H80	20 ¹ / ₄	9	1 ⁷ / ₈	17 ¹¹ / ₁₆	3 ¹ / ₂	24 ³ / ₄	4	³ / ₄	16 ¹ / ₂	14 ³ / ₄	13 ¹ / ₂	³ / ₁₆	¹¹ / ₁₆	1/2 X 1/4 X 2 ³ / ₄	1 ¹ / ₂	NA	1 ³ / ₄
H110	25	11 ³ / ₈	2	18 ¹¹ / ₁₆	3 ¹ / ₂	29 ¹ / ₂	4	1	16 ¹ / ₂	14 ³ / ₄	13 ¹ / ₂	³ / ₁₆	¹¹ / ₁₆	1/2 X 1/4 X 2 ³ / ₄	1 ¹ / ₂	1 ¹ / ₂	2 ¹ / ₈
H125	25	11 ³ / ₈	2	18 ¹¹ / ₁₆	3 ¹ / ₂	29 ¹ / ₂	4	1	16 ¹ / ₂	14 ³ / ₄	13 ¹ / ₂	³ / ₁₆	¹¹ / ₁₆	1/2 X 1/4 X 2 ³ / ₄	1 ¹ / ₂	1 ¹ / ₂	2 ¹ / ₈
H150	30	13 ¹ / ₄	2 ⁷ / ₁₆	22 ³ / ₁₆	4 ³ / ₄	34 ¹ / ₂	4	1	20	14 ³ / ₄	13 ¹ / ₂	³ / ₁₆	¹¹ / ₁₆	5/8 X 5/16 X 3 ³ / ₄	1 ¹⁵ / ₁₆	1 ³ / ₄	2 ³ / ₈
H200	30	13 ¹ / ₄	2 ⁷ / ₁₆	22 ³ / ₁₆	4 ³ / ₄	34 ¹ / ₂	4	1	20	14 ³ / ₄	13 ¹ / ₂	³ / ₁₆	¹¹ / ₁₆	5/8 X 5/16 X 3 ³ / ₄	1 ¹⁵ / ₁₆	1 ³ / ₄	2 ³ / ₈
H250	34 ¹ / ₄	15	2 ³ / ₄	25 ¹¹ / ₁₆	5 ¹ / ₂	40	5 ¹ / ₄	1 ¹ / ₈	20	14 ³ / ₄	13 ¹ / ₂	³ / ₁₆	¹¹ / ₁₆	5/8 X 5/16 X 4 ³ / ₄	2	2	2 ⁵ / ₈
H300	34 ¹ / ₄	15	2 ³ / ₄	25 ¹¹ / ₁₆	5 ¹ / ₂	40	5 ¹ / ₄	1 ¹ / ₈	20	14 ³ / ₄	13 ¹ / ₂	³ / ₁₆	¹¹ / ₁₆	5/8 X 5/16 X 4 ³ / ₄	2	2	2 ⁵ / ₈
H350	38 ¹ / ₂	16 ¹ / ₂	3	30 ¹¹ / ₁₆	5 ¹ / ₂	46	7	1 ¹ / ₄	24 ¹ / ₂	22*	13 ¹ / ₂	³ / ₈	¹⁵ / ₁₆	5/8 X 5/16 X 4 ³ / ₄	2 ³ / ₁₆	2 ³ / ₁₆	3
H425	39 ¹ / ₂	16 ¹ / ₂	3	31 ¹¹ / ₁₆	5 ³ / ₄	46	6 ¹ / ₄	1 ¹ / ₄	24 ¹ / ₂	22*	13 ¹ / ₂	³ / ₈	¹⁵ / ₁₆	3/4 X 3/8 X 4 ³ / ₄	2 ⁷ / ₁₆	2 ⁷ / ₁₆	3 ³ / ₈
H500	39 ¹ / ₂	16 ¹ / ₂	3 ¹ / ₂	32 ¹¹ / ₁₆	6 ³ / ₄	46	6 ¹ / ₄	1 ¹ / ₄	24 ¹ / ₂	22*	13 ¹ / ₂	³ / ₈	¹⁵ / ₁₆	7/8 X 7/16 X 5 ¹ / ₂	2 ⁷ / ₁₆	2 ⁷ / ₁₆	3 ³ / ₈
H600	42 ¹ / ₂	16 ¹ / ₂	3 ³ / ₄	34 ³ / ₄	7 ¹ / ₂	51	8	1 ¹ / ₄	24 ¹ / ₂	22*	13 ¹ / ₂	³ / ₈	¹⁵ / ₁₆	7/8 X 7/16 X 5 ¹ / ₂	2 ¹¹ / ₁₆	2 ¹¹ / ₁₆	4

*Also 5/8-11 Tap on 14-3/4 Bolt Circle 1" Deep
NA - Not Available

TABLE 8. DRIVE SHAFT MODIFICATIONS FOR SPEED DECREASING RATIOS (in inches)

Model	RATIOS	U	XA	N	KEYSEAT X
H150	7:4-2:1-5:2-3:1	2 ¹ / ₄	20 ¹ / ₂	4 ³ / ₄	1/2 X 1/4 X 3 ¹ / ₂
H200	5:2-3:1	2 ¹ / ₄	20 ¹ / ₂	4 ³ / ₄	1/2 X 1/4 X 3 ¹ / ₂
H350	7:4-2:1-9:4	2 ³ / ₄	29	5 ¹ / ₂	5/8 X 5/16 X 4 ¹ / ₂
	11:4-5:2	2 ³ / ₄	30	5 ³ / ₄	5/8 X 5/16 X 4 ¹ / ₂
H425	7:4-2:1-9:4	2 ³ / ₄	30	5 ³ / ₄	5/8 X 5/16 X 4 ¹ / ₂
	5:2-11:4-3:1	2 ³ / ₄	30	5 ³ / ₄	5/8 X 5/16 X 4 ¹ / ₂
H500	7:4-2:1-9:4	2 ³ / ₄	30	5 ³ / ₄	5/8 X 5/16 X 4 ¹ / ₂
	5:2-11:4-3:1	2 ³ / ₄	30	5 ³ / ₄	5/8 X 5/16 X 4 ¹ / ₂
H600	7:4-2:1-9:4	3	31 ¹ / ₂	6	3/4 X 3/8 X 4 ¹ / ₂
	5:2-11:4-3:1	3	31 ¹ / ₂	6	3/4 X 3/8 X 4 ¹ / ₂
H750	4:3-3:2	3 ³ / ₄	36	7 ¹ / ₄	7/8 X 7/16 X 5 ¹ / ₂
	7:4-2:1-9:4	3	34	5 ¹ / ₂	3/4 X 3/8 X 4 ¹ / ₂
	5:2-11:4-3:1	3	34	5 ¹ / ₂	3/4 X 3/8 X 4 ¹ / ₂

ROTATION

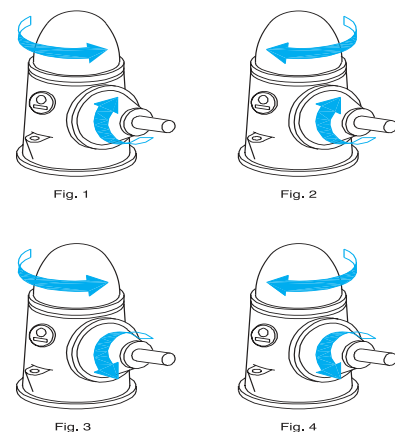

ROTATION DIAGRAM

Gear drives with special rotations (Figs. 2, 3, and 4) and gear drives with speed decreasing ratios of 7:4 or higher are manufactured to order, and such orders are not subject to cancellation without charge for parts processed.

COMBINATION

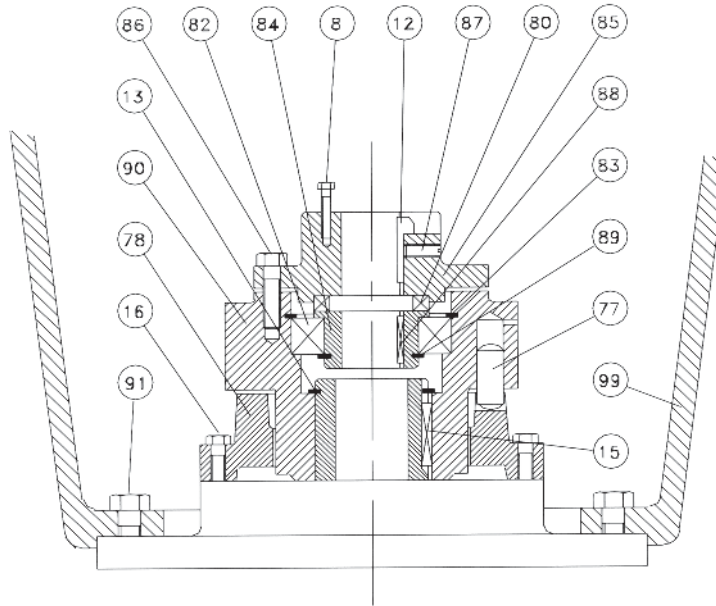

COMBINATION NON-REVERSE

No.	Part Name	No.	Part Name
8	Capscrew	84	Steady Bearing Adaptor
12	Gib Key	85	Upper Coupling Combination
13	External Snap Ring	86	Stainless Steel Capscrews
15	Key (Lower Coupling)	87	Set Screws
16	Capscrew	88	Key (Steady Bearing Adaptor)
77	Ratchet Pins	89	External Snap Ring
78	Thrust Bearing Cover	90	Lower Coupling Combination
80	Wave Spring		Non Reverse
82	Steady Bearing	91	Capscrew
83	Internal Snap Ring	99	Motor Stand

Fast Changeover Prevents Costly Downtime in Emergencies

The Combination Drive—widely preferred by municipalities, waterworks corporations, and those responsible for fire and flood protection—provides pumping assurance when emergencies occur. Either a motor or a mechanical power unit can drive the pump to prevent costly service interruptions. When one of the driving units is down the pump can be operated by the other.

Hollow Shaft Motor. In a normal hollow shaft motor application either a throughshaft or a coupling and shaft combination can be used between the electric motor and the right angle gear drive. When the electric motor is doing the driving, the upper half of the gear drive coupling is free to rotate with the pump headshaft and the gears do not revolve. In case of electric motor or power failure the pump can be driven by a mechanical power unit by simply installing stainless steel bolts, supplied with the gear drive.

The improved coupling design gives better protection to the sealed steady bearing and eliminates the possibility of accidental engagement.

Thrust Load Transfer. If the electric motor has to be removed, the thrust load of the pump can be transferred from the motor thrust bearing to the gear drive. This simply requires adjusting a nut on the pump headshaft to bring the pump impellers to the proper setting.

Solid Shaft Motor. With this type of motor the gear drive carries the thrust load of the pump. The gears revolve when either the electric motor or horizontal drive unit is being used. The recommendation is to use a standard over-running clutch coupling between the engine and the gear drive, and a flexible coupling between the electric motor and the gear drive. (See page 11 for dimensions.)

For various combination drive arrangements consult the factory.

COMBINATION DRIVES - HOLLOW SHAFT

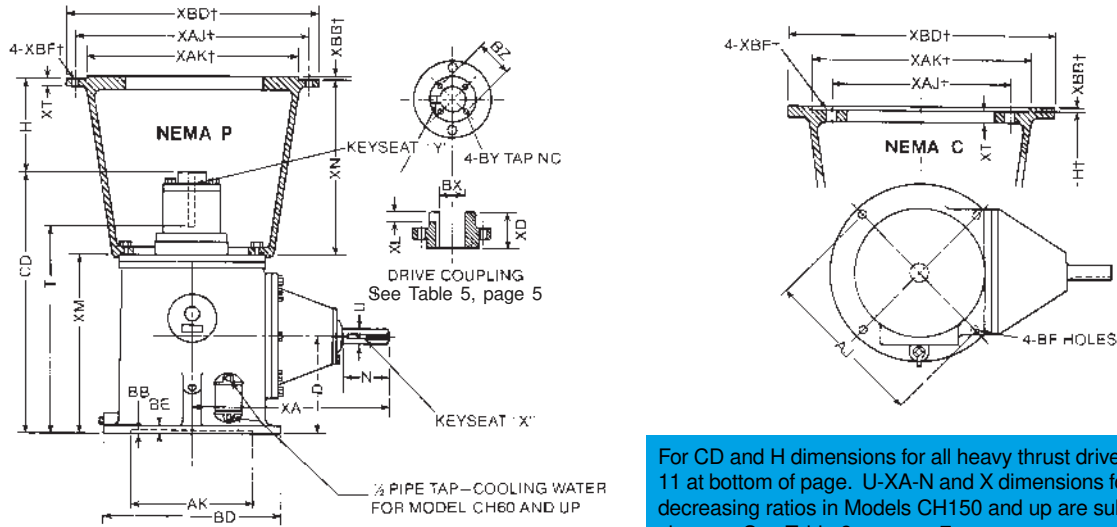

For CD and H dimensions for all heavy thrust drives see Table 11 at bottom of page. U-XA-N and X dimensions for all speed decreasing ratios in Models CH150 and up are subject to change. See Table 8 on page 7.

TABLE 9. COMBINATION DRIVE DIMENSIONS (HOLLOW SHAFT) IN INCHES

Model	CD	D	U	XA	N	XM	H	BE	BD	AJ	AK	BB	BF	Keyseat X
CH20	16	6 ³ / ₈	1 ¹ / ₈	13	2 ³ / ₄	11 ¹ / ₄	7 ³ / ₄	5 ⁵ / ₈	10	9 ¹ / ₈	8 ¹ / ₄	3 ¹ / ₁₆	7 ¹ / ₁₆	1 ¹ / ₄ x 1 ¹ / ₈ x 2 ¹ / ₄
CH40 (12)	22 ¹ / ₄	9	1 ¹ / ₂	16	3 ¹ / ₂	15 ¹ / ₄	9	3 ³ / ₄	12	9 ¹ / ₈	8 ¹ / ₄	3 ¹ / ₁₆	7 ¹ / ₁₆	3 ³ / ₈ x 3 ³ / ₁₆ x 2 ³ / ₄
CH40	22 ¹ / ₄	9	1 ¹ / ₂	16	3 ¹ / ₂	15 ¹ / ₄	9	3 ³ / ₄	16 ¹ / ₂	14 ³ / ₄	13 ¹ / ₂	3 ¹ / ₁₆	11 ¹ / ₁₆	3 ³ / ₈ x 3 ³ / ₁₆ x 2 ³ / ₄
CH60	22 ¹ / ₄	9	1 ¹ / ₂	16	3 ¹ / ₂	15 ¹ / ₄	9	3 ³ / ₄	16 ¹ / ₂	14 ³ / ₄	13 ¹ / ₂	3 ¹ / ₁₆	11 ¹ / ₁₆	3 ³ / ₈ x 3 ³ / ₁₆ x 2 ³ / ₄
CH80	22 ¹ / ₄	9	1 ⁷ / ₈	16 ¹ / ₂	3 ¹ / ₂	15 ¹ / ₄	9	3 ³ / ₄	16 ¹ / ₂	14 ³ / ₄	13 ¹ / ₂	3 ¹ / ₁₆	11 ¹ / ₁₆	1 ¹ / ₂ x 1 ¹ / ₄ x 2 ³ / ₄
CH110	26 ³ / ₄	11 ³ / ₈	2	17 ¹ / ₂	3 ¹ / ₂	19 ⁵ / ₈	9 ⁷ / ₈	1	16 ¹ / ₂	14 ³ / ₄	13 ¹ / ₂	3 ¹ / ₁₆	11 ¹ / ₁₆	1 ¹ / ₂ x 1 ¹ / ₄ x 2 ³ / ₄
CH125	26 ³ / ₄	11 ³ / ₈	2	17 ¹ / ₂	3 ¹ / ₂	19 ⁵ / ₈	9 ⁷ / ₈	1	16 ¹ / ₂	14 ³ / ₄	13 ¹ / ₂	3 ¹ / ₁₆	11 ¹ / ₁₆	1 ¹ / ₂ x 1 ¹ / ₄ x 2 ³ / ₄
CH150	31 ³ / ₄	13 ¹ / ₄	2 ⁷ / ₁₆	20 ¹ / ₂	4 ³ / ₄	23 ¹ / ₈	10 ³ / ₈	1	20	14 ³ / ₄	13 ¹ / ₂	3 ¹ / ₁₆	11 ¹ / ₁₆	5 ⁵ / ₈ x 5 ⁵ / ₁₆ x 3 ³ / ₄
CH200	31 ³ / ₄	13 ¹ / ₄	2 ⁷ / ₁₆	20 ¹ / ₂	4 ³ / ₄	23 ¹ / ₈	10 ³ / ₈	1	20	14 ³ / ₄	13 ¹ / ₂	3 ¹ / ₁₆	11 ¹ / ₁₆	5 ⁵ / ₈ x 5 ⁵ / ₁₆ x 3 ³ / ₄
CH250	36	15	2 ³ / ₄	24	5 ¹ / ₂	26 ⁵ / ₈	12 ³ / ₈	1 ¹ / ₈	20	14 ³ / ₄	13 ¹ / ₂	3 ¹ / ₁₆	11 ¹ / ₁₆	5 ⁵ / ₈ x 5 ⁵ / ₁₆ x 4 ³ / ₄
CH300	36	15	2 ³ / ₄	24	5 ¹ / ₂	26 ⁵ / ₈	12 ³ / ₈	1 ¹ / ₈	20	14 ³ / ₄	13 ¹ / ₂	3 ¹ / ₁₆	11 ¹ / ₁₆	5 ⁵ / ₈ x 5 ⁵ / ₁₆ x 4 ³ / ₄
CH350	40 ¹ / ₂	16 ¹ / ₂	2 ³ / ₄	29	5 ¹ / ₂	29 ⁷ / ₈	13 ³ / ₈	1 ¹ / ₄	24 ¹ / ₂	22*	13 ¹ / ₂	3 ¹ / ₈	15 ¹ / ₁₆	5 ⁵ / ₈ x 5 ⁵ / ₁₆ x 4 ³ / ₄
CH425	41 ³ / ₄	16 ¹ / ₂	3	30	5 ³ / ₄	29 ⁷ / ₈	12 ¹ / ₈	1 ¹ / ₄	24 ¹ / ₂	22*	13 ¹ / ₂	3 ¹ / ₈	15 ¹ / ₁₆	3 ³ / ₄ x 3 ³ / ₈ x 4 ³ / ₄
CH500	41 ³ / ₄	16 ¹ / ₂	3 ¹ / ₂	31	6 ³ / ₄	29 ⁷ / ₈	12 ¹ / ₈	1 ¹ / ₄	24 ¹ / ₂	22*	13 ¹ / ₂	3 ¹ / ₈	15 ¹ / ₁₆	7 ⁷ / ₈ x 7 ⁷ / ₁₆ x 5 ¹ / ₂
CH600	45 ¹ / ₄	16 ¹ / ₂	3 ³ / ₄	33	7 ¹ / ₂	31 ⁷ / ₈	10 ¹ / ₂	1 ¹ / ₄	24 ¹ / ₂	22*	13 ¹ / ₂	3 ¹ / ₈	15 ¹ / ₁₆	7 ⁷ / ₈ x 7 ⁷ / ₁₆ x 5 ¹ / ₂

TABLE 10. MAX. DRIVE COUPLING BORE SIZE AVAILABLE MOTOR STAND

H as determined using maximum XN, *Also 5/8-11 Tap on 14-3/4 Bolt Circle 1" Deep, NA-Not available

Model	XD	Max. BX		T	MOTOR STAND		XT	Top† Flange
		Fig. 1 & 4	Fig. 2 & 3		XN	SPECIAL		
CH20	1 ³ / ₄	1	NA	13 ¹ / ₄	12 ¹ / ₂	10	1 ¹ / ₂	Dimensions XBD, XAJ, XAK, XBB, and XBF to suit NEMA "P" or "C" electric motors.
CH40	2 ³ / ₈	1 ¹ / ₂	1 ¹ / ₄	18	16	12 ¹ / ₂	5 ⁵ / ₈	
CH60	2 ³ / ₈	1 ¹ / ₂	1 ¹ / ₄	18	16	12 ¹ / ₂	5 ⁵ / ₈	
CH80	2 ³ / ₈	1 ¹ / ₂	NA	18	16	12 ¹ / ₂	5 ⁵ / ₈	
CH110	2 ³ / ₈	1 ¹ / ₂	1 ¹ / ₂	23	17	---	3 ³ / ₄	
CH125	2 ³ / ₈	1 ¹ / ₂	1 ¹ / ₂	23	17	---	3 ³ / ₄	
CH150	2 ³ / ₈	1 ³ / ₄	1 ³ / ₄	27 ¹ / ₂	19	---	3 ³ / ₄	
CH200	2 ³ / ₈	1 ³ / ₄	1 ³ / ₄	27 ¹ / ₂	19	---	3 ³ / ₄	
CH250	2 ⁵ / ₈	2	2	31 ¹ / ₂	22	---	3 ³ / ₄	
CH300	2 ⁵ / ₈	2	2	31 ¹ / ₂	22	---	3 ³ / ₄	
CH350	3 ¹ / ₈	2 ³ / ₁₆	2 ³ / ₁₆	35 ¹ / ₂	24	15	1	
CH425	3 ³ / ₈	2 ⁷ / ₁₆	2 ⁷ / ₁₆	35 ³ / ₄	24	15	1	
CH500	3 ³ / ₈	2 ⁷ / ₁₆	2 ⁷ / ₁₆	35 ³ / ₄	24	15	1	
CH600	4	2 ¹¹ / ₁₆	2 ¹¹ / ₁₆	38 ¹ / ₄	24	---	1	

SPECIAL MOTOR STANDS AVAILABLE FOR MODELS LISTED. CONSULT FACTORY FOR DETAILS.

TABLE 11. COMBINATION DRIVE HEAVY THRUST DIMENSIONS

Model	CD	H	T
CH80HT	22 ³ / ₄	8 ¹ / ₄	19 ¹ / ₄
CH110HT	28	8 ⁵ / ₈	24 ¹ / ₄
CH125HT	28	8 ⁵ / ₈	24 ¹ / ₄
CH150HT	33 ¹ / ₄	8 ⁷ / ₈	29
CH200HT	33 ¹ / ₄	8 ⁷ / ₈	29
CH250HT	37 ³ / ₄	10 ⁵ / ₈	33 ¹ / ₄
CH300HT	37 ³ / ₄	10 ⁵ / ₈	33 ¹ / ₄
CH350HT	42 ¹ / ₄	11 ⁵ / ₈	37 ¹ / ₄
CH425HT	43 ³ / ₄	10 ¹ / ₈	37 ³ / ₄
CH500HT	44 ¹ / ₂	9 ³ / ₈	38 ¹ / ₂
CH600HT	45 ¹ / ₄	10 ¹ / ₂	38 ¹ / ₄

The combination drive is desirable where 24-hour service is mandatory and is preferred by municipalities and waterworks corporations. Electric motor or engine may be used to drive the pump, permitting removal of either for repairs without interrupting service. As with the standard drive, combination applications are also available with solid shaft construction. See page 10.

SOLID SHAFT STANDARD TYPES

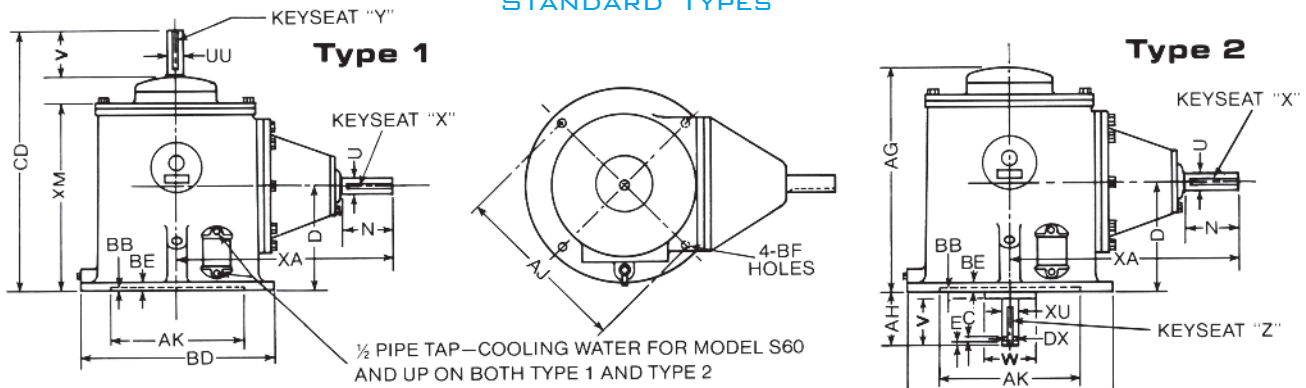

All shaft dimensions for preliminary use only. Contact factory for certified prints

TABLE 12. SOLID SHAFT STANDARD DRIVE DIMENSIONS (IN INCHES)

Model	D	U	XA	N	BE	BD	AJ	AK	BB	BF	Keyseat X
S20	6 ³ / ₈	1 ¹ / ₈	13	2 ³ / ₄	5 ⁵ / ₈	10	9 ¹ / ₈	8 ¹ / ₄	3 ³ / ₁₆	7 ⁷ / ₁₆	1 ¹ / ₄ x 1 ¹ / ₈ x 2 ¹ / ₄
S40 (12)	9	1 ¹ / ₂	16	3 ¹ / ₂	3 ³ / ₄	12	9 ¹ / ₈	8 ¹ / ₄	3 ³ / ₁₆	7 ⁷ / ₁₆	3 ³ / ₈ x 3 ³ / ₁₆ x 2 ³ / ₄
S40	9	1 ¹ / ₂	16	3 ¹ / ₂	3 ³ / ₄	16 ¹ / ₂	14 ³ / ₄	13 ¹ / ₂	3 ³ / ₁₆	11 ¹¹ / ₁₆	3 ³ / ₈ x 3 ³ / ₁₆ x 2 ³ / ₄
S60	9	1 ¹ / ₂	16	3 ¹ / ₂	3 ³ / ₄	16 ¹ / ₂	14 ³ / ₄	13 ¹ / ₂	3 ³ / ₁₆	11 ¹¹ / ₁₆	3 ³ / ₈ x 3 ³ / ₁₆ x 2 ³ / ₄
S80	9	1 ⁷ / ₈	16 ¹ / ₂	3 ¹ / ₂	3 ³ / ₄	16 ¹ / ₂	14 ³ / ₄	13 ¹ / ₂	3 ³ / ₁₆	11 ¹¹ / ₁₆	1 ¹ / ₂ x 1 ¹ / ₄ x 2 ³ / ₄
S110	11 ³ / ₈	2	17 ¹ / ₂	3 ¹ / ₂	1	16 ¹ / ₂	14 ³ / ₄	13 ¹ / ₂	3 ³ / ₁₆	11 ¹¹ / ₁₆	1 ¹ / ₂ x 1 ¹ / ₄ x 2 ³ / ₄
S125	11 ³ / ₈	2	17 ¹ / ₂	3 ¹ / ₂	1	16 ¹ / ₂	14 ³ / ₄	13 ¹ / ₂	3 ³ / ₁₆	11 ¹¹ / ₁₆	1 ¹ / ₂ x 1 ¹ / ₄ x 2 ³ / ₄
S150	13 ¹ / ₄	2 ⁷ / ₁₆	20 ¹ / ₂	4 ³ / ₄	1	20	14 ³ / ₄	13 ¹ / ₂	3 ³ / ₁₆	11 ¹¹ / ₁₆	5 ⁵ / ₈ x 5 ⁵ / ₁₆ x 3 ³ / ₄
S200	13 ¹ / ₄	2 ⁷ / ₁₆	20 ¹ / ₂	4 ³ / ₄	1	20	14 ³ / ₄	13 ¹ / ₂	3 ³ / ₁₆	11 ¹¹ / ₁₆	5 ⁵ / ₈ x 5 ⁵ / ₁₆ x 3 ³ / ₄
S250	15	2 ³ / ₄	24	5 ¹ / ₂	1 ¹ / ₈	20	14 ³ / ₄	13 ¹ / ₂	3 ³ / ₁₆	11 ¹¹ / ₁₆	5 ⁵ / ₈ x 5 ⁵ / ₁₆ x 4 ³ / ₄
S300	15	2 ³ / ₄	24	5 ¹ / ₂	1 ¹ / ₈	20	14 ³ / ₄	13 ¹ / ₂	3 ³ / ₁₆	11 ¹¹ / ₁₆	5 ⁵ / ₈ x 5 ⁵ / ₁₆ x 4 ³ / ₄
S350	16 ¹ / ₂	2 ³ / ₄	29	5 ¹ / ₂	1 ¹ / ₄	24 ¹ / ₂	22*	13 ¹ / ₂	3 ³ / ₈	15 ¹⁵ / ₁₆	5 ⁵ / ₈ x 5 ⁵ / ₁₆ x 4 ³ / ₄
S425	16 ¹ / ₂	3	30	5 ³ / ₄	1 ¹ / ₄	24 ¹ / ₂	22*	13 ¹ / ₂	3 ³ / ₈	15 ¹⁵ / ₁₆	3 ³ / ₄ x 3 ³ / ₈ x 4 ³ / ₄
S500	16 ¹ / ₂	3 ¹ / ₂	31	6 ³ / ₄	1 ¹ / ₄	24 ¹ / ₂	22*	13 ¹ / ₂	3 ³ / ₈	15 ¹⁵ / ₁₆	7 ⁷ / ₈ x 7 ⁷ / ₁₆ x 5 ¹ / ₂
S600	16 ¹ / ₂	3 ³ / ₄	33	7 ¹ / ₂	1 ¹ / ₄	24 ¹ / ₂	22*	13 ¹ / ₂	3 ³ / ₈	15 ¹⁵ / ₁₆	7 ⁷ / ₈ x 7 ⁷ / ₁₆ x 5 ¹ / ₂

* Also 5/8-11 Tap on 14-3/4 Bolt Circle 1" Deep

TABLE 13.

Model	Type 1					Type 2								
	CD	UU	V	Y	XM	XU	AH	AG	Z	DX	C	E	V	W
S20	16 ¹ / ₄	1 ¹ / ₈	2 ³ / ₄	1 ¹ / ₄	11 ¹ / ₄	11 ¹ / ₄	3 ¹ / ₄	13 ³ / ₄	1 ¹ / ₄	1	3 ³ / ₈	3 ³ / ₈	2 ³ / ₈	4 ³ / ₄
S40(12)	22	1 ³ / ₄	3 ⁷ / ₈	3 ³ / ₈	15 ¹ / ₄	17 ³ / ₈	4 ³ / ₄	18 ¹ / ₂	1 ¹ / ₂	11 ¹ / ₂	3 ³ / ₈	3 ³ / ₈	3 ⁷ / ₈	5
S40	22	1 ³ / ₄	3 ⁷ / ₈	3 ³ / ₈	15 ¹ / ₄	17 ³ / ₈	4 ³ / ₄	18 ¹ / ₂	1 ¹ / ₂	11 ¹ / ₂	3 ³ / ₈	3 ³ / ₈	3 ⁷ / ₈	5
S60	22	1 ³ / ₄	3 ⁷ / ₈	3 ³ / ₈	15 ¹ / ₄	17 ³ / ₈	4 ³ / ₄	18 ¹ / ₂	1 ¹ / ₂	11 ¹ / ₂	3 ³ / ₈	3 ³ / ₈	3 ⁷ / ₈	5
S80	22	1 ³ / ₄	3 ⁷ / ₈	3 ³ / ₈	15 ¹ / ₄	17 ³ / ₈	4 ³ / ₄	18 ¹ / ₂	1 ¹ / ₂	11 ¹ / ₂	3 ³ / ₈	3 ³ / ₈	3 ⁷ / ₈	5
S110	27	2 ¹ / ₈	4 ¹ / ₂	1 ¹ / ₂	19 ⁵ / ₈	21 ³ / ₈	5	22 ¹ / ₂	1 ¹ / ₂	13 ¹ / ₄	3 ³ / ₈	3 ³ / ₈	4 ¹ / ₂	8 ¹ / ₈
S125	27	2 ¹ / ₈	4 ¹ / ₂	1 ¹ / ₂	19 ⁵ / ₈	21 ³ / ₈	5	22 ¹ / ₂	1 ¹ / ₂	13 ¹ / ₄	3 ³ / ₈	3 ³ / ₈	4 ¹ / ₂	8 ¹ / ₈
S150	31 ¹ / ₂	2 ³ / ₈	4 ¹ / ₂	5 ⁵ / ₈	23 ¹ / ₈	23 ³ / ₈	6	27 ¹ / ₄	5 ⁵ / ₈	2	3 ³ / ₈	3 ³ / ₈	5 ³ / ₄	9 ¹ / ₄
S200	31 ¹ / ₂	2 ³ / ₈	4 ¹ / ₂	5 ⁵ / ₈	23 ¹ / ₈	23 ³ / ₈	6	27 ¹ / ₄	5 ⁵ / ₈	2	3 ³ / ₈	3 ³ / ₈	5 ³ / ₄	9 ¹ / ₄
S250	35 ³ / ₈	2 ⁵ / ₈	4 ³ / ₄	5 ⁵ / ₈	26 ³ / ₄	2 ⁵ / ₈	6	31	5 ⁵ / ₈	2 ¹ / ₄	3 ³ / ₈	3 ³ / ₈	5 ³ / ₄	9 ¹ / ₄
S300	35 ³ / ₈	2 ⁵ / ₈	4 ³ / ₄	5 ⁵ / ₈	26 ³ / ₄	2 ⁵ / ₈	6	31	5 ⁵ / ₈	2 ¹ / ₄	3 ³ / ₈	3 ³ / ₈	5 ³ / ₄	9 ¹ / ₄
S350	39	2 ⁵ / ₈	4 ³ / ₄	5 ⁵ / ₈	29 ⁷ / ₈	2 ⁵ / ₈	6	34 ³ / ₄	5 ⁵ / ₈	2 ¹ / ₄	3 ³ / ₈	3 ³ / ₈	5 ³ / ₄	10 ¹ / ₂
S425	40 ¹ / ₄	3 ¹ / ₂	4 ³ / ₄	7 ⁷ / ₈	29 ⁷ / ₈	3 ¹ / ₄	7 ¹ / ₄	36	3 ³ / ₄	2 ³ / ₄	1 ¹ / ₂	1 ¹ / ₂	6	10 ¹ / ₂
S500	40 ¹ / ₄	3 ¹ / ₂	5 ¹ / ₄	7 ⁷ / ₈	29 ⁷ / ₈	3 ¹ / ₄	7 ¹ / ₄	36	3 ³ / ₄	2 ³ / ₄	1 ¹ / ₂	1 ¹ / ₂	6	10 ¹ / ₂
S600	43 ¹ / ₂	3 ¹ / ₂	5 ¹ / ₂	7 ⁷ / ₈	31 ⁷ / ₈	3 ³ / ₄	8	38 ¹ / ₂	7 ⁷ / ₈	3 ¹ / ₄	1 ¹ / ₂	1 ¹ / ₂	6	10 ¹ / ₂

♦ For Dimensions of S750-H1500 Contact Factory.

ROTATION

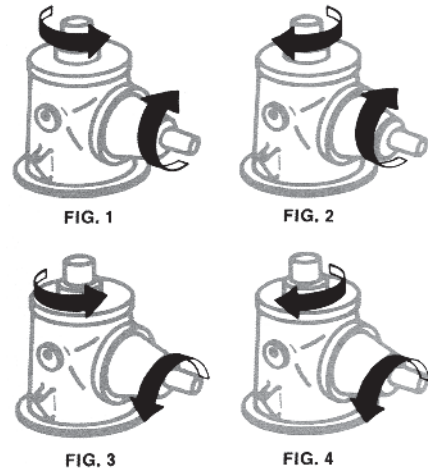

All solid gear drives are manufactured to order, and such orders are not subject to cancellation without charge for parts processed.

SOLID SHAFT COMBINATION TYPE 3

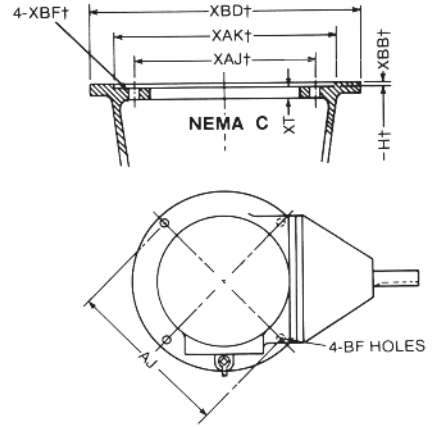
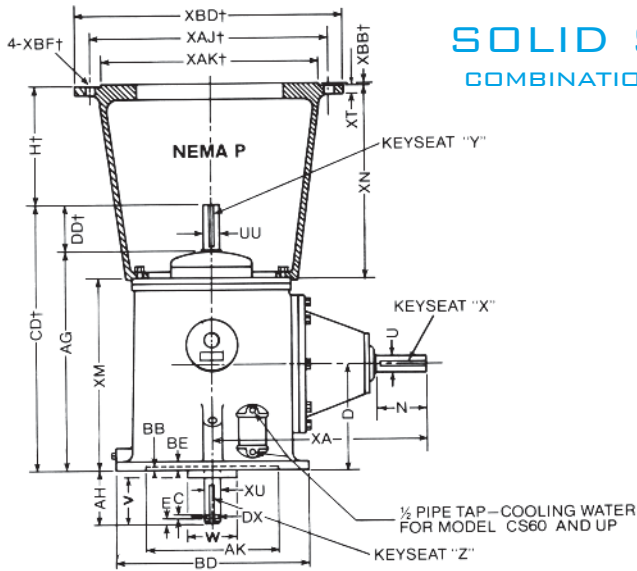

All shaft dimensions for preliminary use only.
Contact factory for certified prints

TABLE 14. SOLID SHAFT STANDARD DRIVE DIMENSIONS (IN INCHES)

Model	D	U	XA	N	BE	BD	AJ	AK	BB	BF	XU	AH	Keyseat X	Z
CS20	6 ³ / ₈	1 ¹ / ₂	13	2 ³ / ₄	5 ⁵ / ₈	10	9 ¹ / ₈	8 ¹ / ₄	3 ³ / ₁₆	7 ⁷ / ₁₆	1 ¹ / ₄	3 ¹ / ₄	1 ¹ / ₄ x 1 ¹ / ₈ x 2 ¹ / ₄	1 ¹ / ₄
CS40 (12)	9	1 ¹ / ₂	16	3 ¹ / ₂	3 ³ / ₄	12	9 ¹ / ₈	8 ¹ / ₄	3 ³ / ₁₆	7 ⁷ / ₁₆	1 ⁷ / ₈	4 ³ / ₄	3 ³ / ₈ x 3 ³ / ₁₆ x 2 ³ / ₄	1 ¹ / ₂
CS40	9	1 ¹ / ₂	16	3 ¹ / ₂	3 ³ / ₄	16 ¹ / ₂	14 ³ / ₄	13 ¹ / ₂	3 ³ / ₁₆	1 ¹¹ / ₁₆	1 ⁷ / ₈	4 ³ / ₄	3 ³ / ₈ x 3 ³ / ₁₆ x 2 ³ / ₄	1 ¹ / ₂
CS60	9	1 ¹ / ₂	16	3 ¹ / ₂	3 ³ / ₄	16 ¹ / ₂	14 ³ / ₄	13 ¹ / ₂	3 ³ / ₁₆	1 ¹¹ / ₁₆	1 ⁷ / ₈	4 ³ / ₄	3 ³ / ₈ x 3 ³ / ₁₆ x 2 ³ / ₄	1 ¹ / ₂
CS80	9	1 ⁷ / ₈	16 ¹ / ₂	3 ¹ / ₂	3 ³ / ₄	16 ¹ / ₂	14 ³ / ₄	13 ¹ / ₂	3 ³ / ₁₆	1 ¹¹ / ₁₆	1 ⁷ / ₈	4 ³ / ₄	1 ¹ / ₂ x 1 ¹ / ₄ x 2 ³ / ₄	1 ¹ / ₂
CS110	11 ³ / ₈	2	17 ¹ / ₂	3 ¹ / ₂	1	16 ¹ / ₂	14 ³ / ₄	13 ¹ / ₂	3 ³ / ₁₆	1 ¹¹ / ₁₆	2 ¹ / ₈	5	1 ¹ / ₂ x 1 ¹ / ₄ x 2 ³ / ₄	1 ¹ / ₂
CS125	11 ³ / ₈	2	17 ¹ / ₂	3 ¹ / ₂	1	16 ¹ / ₂	14 ³ / ₄	13 ¹ / ₂	3 ³ / ₁₆	1 ¹¹ / ₁₆	2 ¹ / ₈	5	1 ¹ / ₂ x 1 ¹ / ₄ x 2 ³ / ₄	1 ¹ / ₂
CS150	13 ¹ / ₄	2 ⁷ / ₁₆	20 ¹ / ₂	4 ³ / ₄	1	20	14 ³ / ₄	13 ¹ / ₂	3 ³ / ₁₆	1 ¹¹ / ₁₆	2 ³ / ₈	6	5 ⁵ / ₈ x 5 ⁵ / ₁₆ x 3 ³ / ₄	5 ⁵ / ₈
CS200	13 ¹ / ₄	2 ⁷ / ₁₆	20 ¹ / ₂	4 ³ / ₄	1	20	14 ³ / ₄	13 ¹ / ₂	3 ³ / ₁₆	1 ¹¹ / ₁₆	2 ³ / ₈	6	5 ⁵ / ₈ x 5 ⁵ / ₁₆ x 3 ³ / ₄	5 ⁵ / ₈
CS250	15	2 ³ / ₄	24	5 ¹ / ₂	1 ¹ / ₈	20	14 ³ / ₄	13 ¹ / ₂	3 ³ / ₁₆	1 ¹¹ / ₁₆	2 ⁵ / ₈	6	5 ⁵ / ₈ x 5 ⁵ / ₁₆ x 4 ³ / ₄	5 ⁵ / ₈
CS300	15	2 ³ / ₄	24	5 ¹ / ₂	1 ¹ / ₈	20	14 ³ / ₄	13 ¹ / ₂	3 ³ / ₁₆	1 ¹¹ / ₁₆	2 ⁵ / ₈	6	5 ⁵ / ₈ x 5 ⁵ / ₁₆ x 4 ³ / ₄	5 ⁵ / ₈
CS350	16 ¹ / ₂	2 ³ / ₄	29	5 ¹ / ₂	1 ¹ / ₄	24 ¹ / ₂	22*	13 ¹ / ₂	3 ³ / ₈	1 ¹⁵ / ₁₆	2 ⁵ / ₈	6	5 ⁵ / ₈ x 5 ⁵ / ₁₆ x 4 ³ / ₄	5 ⁵ / ₈
CS425	16 ¹ / ₂	3	30	5 ³ / ₄	1 ¹ / ₄	24 ¹ / ₂	22*	13 ¹ / ₂	3 ³ / ₈	1 ¹⁵ / ₁₆	3 ¹ / ₄	7 ¹ / ₄	3 ³ / ₄ x 3 ³ / ₈ x 4 ³ / ₄	3 ³ / ₄
CS500	16 ¹ / ₂	3 ¹ / ₂	31	6 ³ / ₄	1 ¹ / ₄	24 ¹ / ₂	22*	13 ¹ / ₂	3 ³ / ₈	1 ¹⁵ / ₁₆	3 ¹ / ₄	7 ¹ / ₄	7 ⁷ / ₈ x 7 ⁷ / ₁₆ x 5 ¹ / ₂	3 ³ / ₄
CS600	16 ¹ / ₂	3 ³ / ₄	33	7 ¹ / ₂	1 ¹ / ₄	24 ¹ / ₂	22*	13 ¹ / ₂	3 ³ / ₈	1 ¹⁵ / ₁₆	3 ³ / ₄	8	7 ⁷ / ₈ x 7 ⁷ / ₁₆ x 5 ¹ / ₂	7 ⁷ / ₈

* Also 5/8-11 Tap on 14-3/4 Bolt Circle 1" Deep

TABLE 15.

Model	UU	AG	XM	XT	MOTOR STAND		Y	DX	C	E	V	W
					XN	SPECIAL						
CS20	1 ¹ / ₈	13 ¹ / ₂	11 ¹ / ₄	1 ¹ / ₂	12 ¹ / ₂	10	1 ¹ / ₄	1	3 ³ / ₈	3 ³ / ₈	2 ³ / ₈	4 ³ / ₄
CS40(12)	1 ³ / ₄	18 ¹ / ₈	15 ¹ / ₄	5 ⁵ / ₈	16	12 ¹ / ₂	3 ³ / ₈	1 ¹ / ₂	3 ³ / ₈	3 ³ / ₈	3 ⁷ / ₈	5
CS40	1 ³ / ₄	18 ¹ / ₈	15 ¹ / ₄	5 ⁵ / ₈	16	12 ¹ / ₂	3 ³ / ₈	1 ¹ / ₂	3 ³ / ₈	3 ³ / ₈	3 ⁷ / ₈	5
CS60	1 ³ / ₄	18 ¹ / ₈	15 ¹ / ₄	5 ⁵ / ₈	16	12 ¹ / ₂	3 ³ / ₈	1 ¹ / ₂	3 ³ / ₈	3 ³ / ₈	3 ⁷ / ₈	5
CS80	1 ³ / ₄	18 ¹ / ₈	15 ¹ / ₄	5 ⁵ / ₈	16	12 ¹ / ₂	3 ³ / ₈	1 ¹ / ₂	3 ³ / ₈	3 ³ / ₈	3 ⁷ / ₈	5
CS110	2 ¹ / ₈	22 ¹ / ₂	19 ⁵ / ₈	3 ³ / ₄	17	-	1 ¹ / ₂	1 ³ / ₄	3 ³ / ₈	3 ³ / ₈	4 ¹ / ₂	8 ¹ / ₈
CS125	2 ¹ / ₈	22 ¹ / ₂	19 ⁵ / ₈	3 ³ / ₄	17	-	1 ¹ / ₂	1 ³ / ₄	3 ³ / ₈	3 ³ / ₈	4 ¹ / ₂	8 ¹ / ₈
CS150	2 ³ / ₈	27	23 ¹ / ₈	3 ³ / ₄	19	-	5 ⁵ / ₈	2	3 ³ / ₈	3 ³ / ₈	5 ³ / ₄	9 ¹ / ₄
CS200	2 ³ / ₈	27	23 ¹ / ₈	3 ³ / ₄	19	-	5 ⁵ / ₈	2	3 ³ / ₈	3 ³ / ₈	5 ³ / ₄	9 ¹ / ₄
CS250	2 ⁵ / ₈	30 ⁵ / ₈	26 ³ / ₈	3 ³ / ₄	22	-	5 ⁵ / ₈	2 ¹ / ₄	3 ³ / ₈	3 ³ / ₈	5 ³ / ₄	9 ¹ / ₄
CS300	2 ⁵ / ₈	30 ⁵ / ₈	26 ³ / ₈	3 ³ / ₄	22	15	5 ⁵ / ₈	2 ¹ / ₄	3 ³ / ₈	3 ³ / ₈	5 ³ / ₄	10 ¹ / ₂
CS350	2 ⁵ / ₈	34 ¹ / ₄	29 ⁷ / ₈	1	24	15	5 ⁵ / ₈	2 ¹ / ₄	3 ³ / ₈	3 ³ / ₈	5 ³ / ₄	10 ¹ / ₂
CS425	3 ¹ / ₂	35 ¹ / ₂	29 ⁷ / ₈	1	24	15	7 ⁷ / ₈	2 ³ / ₄	1 ¹ / ₂	1 ¹ / ₂	6	10 ¹ / ₂
CS500	3 ¹ / ₂	35	29 ⁷ / ₈	1	24	15	7 ⁷ / ₈	2 ³ / ₄	1 ¹ / ₂	1 ¹ / ₂	6	10 ¹ / ₂
CS600	3 ¹ / ₂	38	31 ⁷ / ₈	1	24	-	7 ⁷ / ₈	3 ¹ / ₄	1 ¹ / ₂	1 ¹ / ₂	6	10 ¹ / ₂

† Dimensions XBD, XAJ, XAK, XBB, XBF, DD, CD and H to NEMA "P" or "C" electric motors.

SEE PAGE 5 FOR HOLLOW SHAFT DRIVES

ROTATION

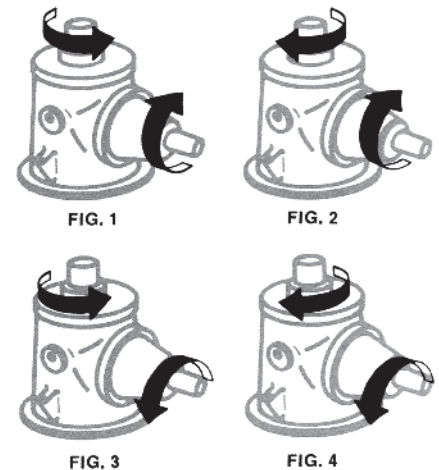

All solid gear drives are manufactured to order, and such orders are not subject to cancellation without charge for parts processed.

REDI-TORQ

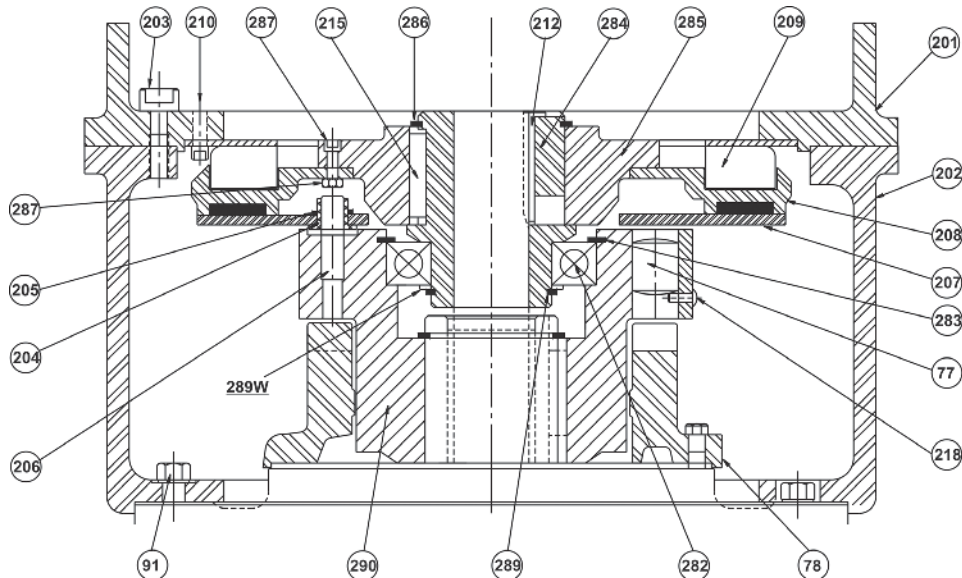

*Drive Plate (207) Shown Engaged - Gap Should Approximately be 3/32 When Disengaged

REDI-TORQ SUB ASSEMBLY

No.	Part Name	No.	Part Name
77	Ratchet Pins	212	Gib Key
78	Thrust Bearing Cover	215	Rotor Hub Key
91	Capscrew	218	Fil. Hd. Screws
201	Upper Motor Stand	282	Steady Bearing
202	Lower Motor Stand	283	Snap Ring
203	Socket Head Capscrew	284	Rotor Bushing
204	Drive Pin Bushings	285	Rotor Hub
205	Retainer Rings	286	Snap Ring
206	Drive Pins	287	Socket Head Capscrew
207	Drive Plate	287N	Flexloc Nuts
208	Rotor	289	Snap Ring
209	Field	289W	Snap Ring Washer
210	Socket Head Capscrew	290	Lower Coupling

Provides Automatic Operation for Pumping Stations and Storm Drainage.

The Redi-Torq drive is desirable where 24-hour service is mandatory and automatic operation is desired. It is preferred by municipalities and waterworks corporations.

Electric motor or engine may be used to drive the pump permitting removal of either for repairs without interrupting service.

Redi-Torq HOLLOW SHAFT DRIVE

Incorporates all of the features of the standard Combination Drive described on page 8 with the added capability of automatic power changeover through a magnetic clutch. Operation is as follows: interruption of electric power initiates starting of engine through the control panel. * Redi-Torq clutch is energized and the engine drives the pump. Return of electric power initiates engine shutdown and returns operation of pump to the electric motor.

The Redi-Torq drive permits the use of standard flexible shafting or coupling between engine and gear drive, and engines need not be equipped with mechanical clutches. Interruption of the Redi-Torq circuit permits testing or tuneup of the engine without affecting the pump shaft. This permits continuous pumping by the electric motor while the engine is being tuned.

**We do not furnish the control system for the Redi-Torq of which there are several standard makes available, in addition to those made by some engine manufacturers and dealers.*

Any control system used should preferably energize the Redi-Torq clutch at engine idle speed or at start of cranking cycle (static engagement). Either method requires a throttle or governor speed control to "gradually" advance the engine from idle to full load speed.

Caution: Engagement of Redi-Torq clutch should never be made at full load speed.

HOLLOW SHAFT REDI-TORQ DRIVE

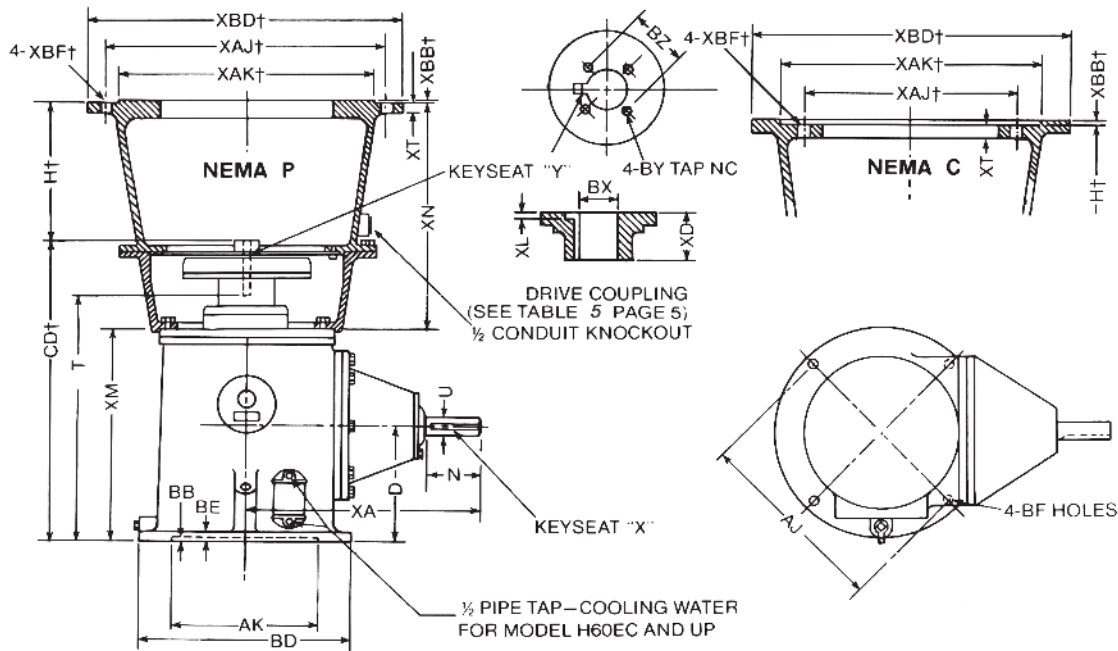

U-XA-N and X dimensions for Models H150EC and H200EC are subject to change. See Table 8 on page 7.

TABLE 16. RED I-TORQ® DRIVE DIMENSIONS (IN INCHES)

Model	CD	D	U	XA	N	XM	H	BD	AJ	AK	BB	BE	BF	Keyseat X	MOTOR STAND	
															XN	XT
H40-12EC	22 ³ / ₄	9	1 ¹ / ₂	16	3 ¹ / ₂	15 ¹ / ₄	9 ¹ / ₈	12	9 ¹ / ₈	8 ¹ / ₄	3 ¹ / ₁₆	3 ³ / ₄	7 ¹ / ₁₆	3 ³ / ₈ × 3 ¹ / ₁₆ × 2 ³ / ₄	16 ⁵ / ₈	5 ⁵ / ₈
H40EC	22 ³ / ₄	9	1 ¹ / ₂	16	3 ¹ / ₂	15 ¹ / ₄	9 ¹ / ₈	16 ¹ / ₂	14 ³ / ₄	13 ¹ / ₂	3 ¹ / ₁₆	3 ³ / ₄	7 ¹ / ₁₆	3 ³ / ₈ × 3 ¹ / ₁₆ × 2 ³ / ₄	16 ⁵ / ₈	5 ⁵ / ₈
H60EC	22 ³ / ₄	9	1 ¹ / ₂	16	3 ¹ / ₂	15 ¹ / ₄	9 ¹ / ₈	16 ¹ / ₂	14 ³ / ₄	13 ¹ / ₂	3 ¹ / ₁₆	3 ³ / ₄	11 ¹ / ₁₆	3 ³ / ₈ × 3 ¹ / ₁₆ × 2 ³ / ₄	16 ⁵ / ₈	5 ⁵ / ₈
H110EC	27 ¹ / ₂	11 ³ / ₈	2	17 ¹ / ₂	3 ¹ / ₂	19 ⁵ / ₈	9 ¹ / ₈	16 ¹ / ₂	14 ³ / ₄	13 ¹ / ₂	3 ¹ / ₁₆	1	11 ¹ / ₁₆	1 ¹ / ₂ × 1 ¹ / ₄ × 2 ³ / ₄	17	5 ⁵ / ₈
H150EC	32 ⁷ / ₈	13 ¹ / ₄	2 ⁷ / ₁₆	20 ¹ / ₂	4 ³ / ₄	23 ¹ / ₈	8 ³ / ₄	20	14 ³ / ₄	13 ¹ / ₂	3 ¹ / ₁₆	1	11 ¹ / ₁₆	5 ³ / ₈ × 5 ¹ / ₁₆ × 3 ³ / ₄	18 ¹ / ₂	3 ³ / ₄
H200EC	32 ⁷ / ₈	13 ¹ / ₄	2 ⁷ / ₁₆	20 ¹ / ₂	4 ³ / ₄	23 ¹ / ₈	8 ³ / ₄	20	14 ³ / ₄	13 ¹ / ₂	3 ¹ / ₁₆	1	11 ¹ / ₁₆	5 ³ / ₈ × 5 ¹ / ₁₆ × 3 ³ / ₄	18 ¹ / ₂	3 ³ / ₄

TABLE 17.

Model	XD	XL	Max. BX		T	CLUTCH VOLTAGE	
			Fig. 1&4	Fig. 2&3		STD	OPT
			H40-12EC	4 ¹ / ₄		1 ¹ / ₄	1 ⁷ / ₁₆
H40EC	4 ¹ / ₄	1 ¹ / ₄	1 ⁷ / ₁₆	1 ¹ / ₄	18 ¹ / ₂	12	6
H60EC	4 ¹ / ₄	1 ¹ / ₄	1 ⁷ / ₁₆	1 ¹ / ₄	18 ¹ / ₂	12	6
H110EC	4 ⁵ / ₈	1 ¹ / ₄	1 ¹ / ₂	1 ¹ / ₂	22 ⁷ / ₈	12	24
H150EC	5 ³ / ₈	1 ¹ / ₄	1 ¹⁵ / ₁₆	1 ³ / ₄	27 ¹ / ₂	12	24
H200EC	5 ³ / ₈	1 ¹ / ₄	1 ¹⁵ / ₁₆	1 ³ / ₄	27 ¹ / ₂	12	24

† Dimensions XBD, XAJ, XAK, XBB, and XBF to suit NEMA "P" or "C" electric motors.

ROTATION

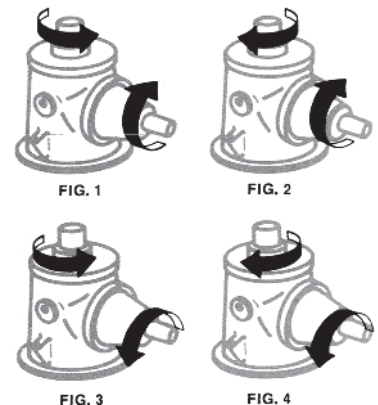

For standard drive coupling size see Table 5 page 5.

All REDI-TORQ drives are manufactured to order, and such orders are not subject to cancellation without charge for parts processed.

TORSIONAL COUPLINGS

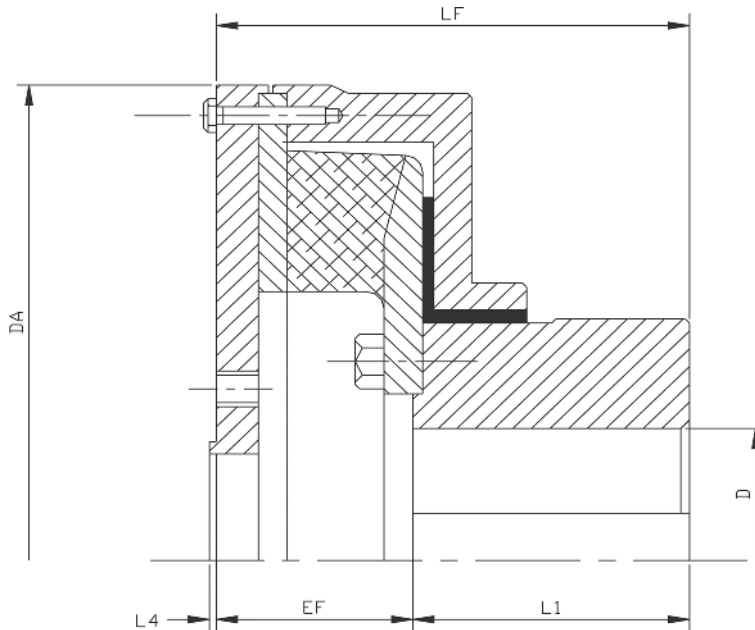

TABLE 18.

TC-VSK coupling size	DA	D	L1	LF	EF	L4	Total weight lb	Compatible Drive Flanges	Application
TC-VSK15-1500	8.740	1.500	2.559	4.094	1.535	0.079	31.6	1350, 1410	H40/60
TC-VSK15-1875	8.740	1.875	2.559	4.094	1.535	0.079	31.6	1480, 1550	H80
TC-VSK25-2000	10.551	2.000	2.559	4.488	1.929	0.079	45.7	1480, 1550, 1610, 1710	H110/125
TC-VSK25-2437	10.551	2.437	2.559	4.488	1.929	0.079	45.7	1480, 1550, 1610, 1710	H150/200
TC-VSK45-2750	12.598	2.750	3.150	5.472	2.347	0.098	88.1	1610, 1710, 1810	H250/300/350
TC-VSK50-3000	14.173	3.000	3.937	6.732	2.795	0.098	119.2	1610, 1710, 1810	H425
TC-VSK50-3500	14.173	3.500	3.937	6.732	2.795	0.098	119.2	1610, 1710, 1810	H500

Increase Your Pumping System Protection

The use of diesel engines to drive right angle drives and pumping systems has increased over recent years and with that, technological improvements in components have caused drastic reductions in engine weight, increased compression ratios and turbo charging. These changes have resulted in the transfer of power from the engine to the driven equipment to not be as smooth as before.

Premature failure of the components in a pump system can occur when operating at or near (+/- 10%) a torsional resonant speed. With engine driven systems, it is not uncommon for one or more resonant speeds to exist between zero (0) rpm and the operating speed of the system. Continued operation at a resonant speed will result in torsional vibrations, which can be damaging to all components in the system. Vibratory torque, much higher than the rated torque of the driven components, is not uncommon.

Typical modes of failure are broken crank shafts, drive line shafts, drive line shafts twisting in two, broken input shafts, and broken gear teeth. Unusual rumbling and clattering noise from the

gear drive at specific speed is the most common indication of torsional vibrations. As the speed is increased or decreased, the noise will disappear. Noise is a result of the gear teeth separating and clashing together very rapidly when the vibratory torque exceeds the drive torque, typically at a resonant speed. Transition through a resonant speed is not normally damaging, but operation at or near the resonant speed, should be avoided.

To avoid operation at a resonant speed, it may be necessary to make a change to the speed of the engine with respect to the pump, or change the elastic characteristics; a torsional coupling needs to be added to the system.

The torsional coupling is designed and installed with systems using U-joint type drive-lines and standard gear drives. The coupling is usually self-supporting and is selected with the best compromise of torsional characteristics for engines operating between 1200 and 2400 rpm. In most cases, the coupling can be installed with minimal modifications to the drive-line shaft and guarding system. Guarding systems, should always be used around rotating shafts and couplings. Johnson

HOW TO ORDER

Please supply the following data when ordering or inquiring about Johnson Right Angle Gear Drives:
STANDARD and COMBINATION DRIVES:

Model _____	Pump Shaft Diameter (BX) _____
Ratio (See Table 1) _____ Pump RPM _____ Drive RPM _____	Duty: Continuous _____ Intermittent _____
Rotation (See diagrams) _____	COMBINATION and REDI-TORQ DRIVES:
Horsepower Required by Pump _____	Motor Stand Information Required (See Table 10)
Maximum Downthrust _____ Upthrust _____	Specify NEMA P or NEMA C frame size.
(See Table 2 for minimum downthrust)	XN _____ XBD _____ XAK _____ XAJ _____
	For combination drives with solid shafts furnish details for coupling.

WARRANTY

1. The Johnson Right Angle Gear Drive is warranted to be free from defects in material and workmanship under normal use and service for a period of one year from the date of factory shipment by us for the original purchaser and then only when operated within the rated capacity for which it was sold and in accordance with recognized usage and practice. Our obligation under this warranty is limited to the replacement of any part or parts which shall be returned to us with transportation charges prepaid, within one year after shipment for the original purchaser; and, which it is determined by the company, to have proven defective under normal and proper use. This warranty shall not apply to any drive which has been altered or repaired outside our factory without our written consent and approval, or any drive which has been subject to misuse, neglect, accident, improper oiling, or torsional damage.

2. We make no warranty of any kind whatever, express or implied, in regard to bearings, trade accessories, machinery, or other articles of merchandise not manufactured by us. The bearings which we have selected for the thrust position will cover most installations, but there are many cases which will require special treatment.

3. Johnson Gear is a supplier of only one component in the pumping system; we have no control over system design, or engine selection. It is the responsibility of those who select the equipment for the pumping project to assure that damage to any component does not occur due to Torsional Vibration. Johnson Gear will award a three-year warranty to any drive that is equipped with a torsional dampening devise, located between the engine flywheel and the gear drive.

4. No warranty or guarantee is binding upon the company and no asserted breach thereof can be claimed against the company unless the company has been notified in detail and in writing of any alleged defect within seven (7) days after the discovery thereof.

5. The express warranties and guarantee contained herein are exclusive and are made in lieu of any other representation by the company or its agents, and any implied warranty of Merchantability or Fitness for a Particular Purpose are hereby expressly disclaimed. It is agreed that the language contained herein shall be the final and exclusive expression of the agreement with respect to sale of equipment by the company.

APPROXIMATE SHIPPING WEIGHTS AND DIMENSIONS

Model	Net Weight Lbs.	Gross Weight. Lbs		Box Dimensions in Inches			Volume
		Domestic & Container	Plywood	Width	Depth	Height	Cu. Ft.
H20	120	145	170	26	19	38	11
H40-12	225	250	280	26	19	38	11
H40	240	265	295	26	19	38	11
H60	250	275	305	26	19	38	11
H80	280	305	335	26	19	38	11
H110	385	410	440	26	19	38	11
H125	395	420	450	26	19	38	11
H150	640	680	720	34	23	47	21
H200	640	680	720	34	23	47	21
H250	900	1000	1050	41	31	54	40
H300	900	1000	1050	41	31	54	40
H350	1350	1470	1520	47	31	56	47
H425	1540	1650	1700	47	31	56	47
H500	1580	1690	1740	47	31	56	47
H600	1970	2100	2200	47	31	56	47
H750	2100	2200	2340	47	31	64	54
H1000	2100	2200	2340	47	31	64	54
H1200	3160	3260	3500	54	36	64	72
H1500	3160	3260	3500	54	36	64	72



JOHNSON GEAR

Right Angle Gear Drive

CELEBRATING 100 YEARS

1905 - 2005

**“Right Angle Gear Drives
For Irrigation, Industrial,
Municipal, and Fire
Protection”**



■ 1333 E. 44TH LUBBOCK, TX 79404 ■ Phone: Toll Free 877-967-6400 ■ Fax: 806-749-6477

Visit Our Website @ www.johnsongear.com