

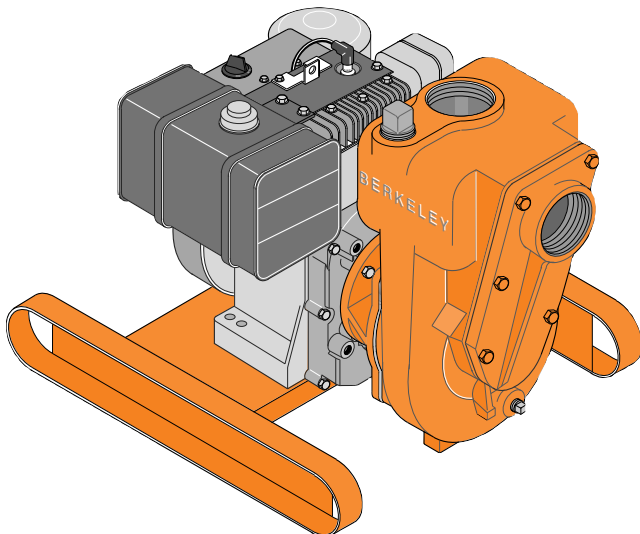

Berkeley Care Manual

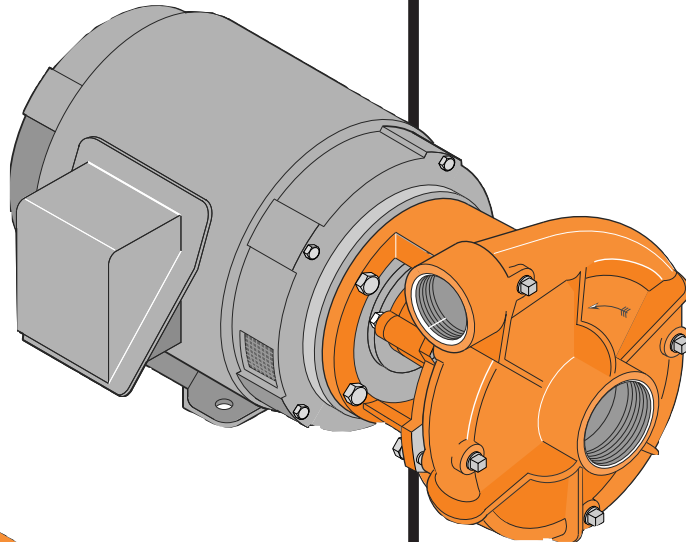
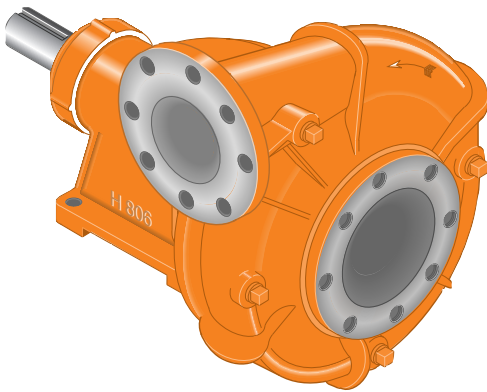

293 Wright Street
Delavan, Wisconsin U.S.A. 53115
1-888-BERKELEY
Mississauga, Ont., Canada
1-800-363-PUMP

Introduction

This Care Manual was designed as a general guide to Berkeley centrifugal pumps and is not intended to be used as an Engineering Specifications Manual.

All subjects covered, whether written or illustrated, are suggestions by Berkeley Pumps to aid in the proper installation and operation of end suction centrifugal pumps and apply to no particular application.

Questions on specific application and/or installation procedures, maintenance, and repair, should be directed to the nearest Berkeley Professional Dealer.

Table of Contents

	Page
• Introduction	2
• Section 1: Installation	3-14
• Section 2: Start-up	15-19
• Section 3: Maintenance	20-28
• Section 4: Pump Nomenclature	29-35

Watch for this symbol



Component damage can occur when excessive force is applied during assembly, disassembly, repair, or maintenance. Generally, components do not need to be forced on or off during these procedures. Use care at all times to protect the physical integrity of all pump components.

SECTION 1

Installation

Contents

	Page
● Suction Connection, Suction Lift – Recommended	4
● Suction Connection, Suction Lift – Not Recommended	5
● Suction Connection, Flooded Suction – Recommended	6
● Suction Connection, Flooded Suction – Not Recommended	7
● Discharge Connection – Recommended	8
● Discharge Connection – Not Recommended	9
● Pump Foundation	10
● Pump Protection, Pump House / Shelter	11
● Shaft Alignment Belt / Coupling Drive	12
● Protect Your Investment	13,14

INSTALLATION

Suction Connection

Suction Lift

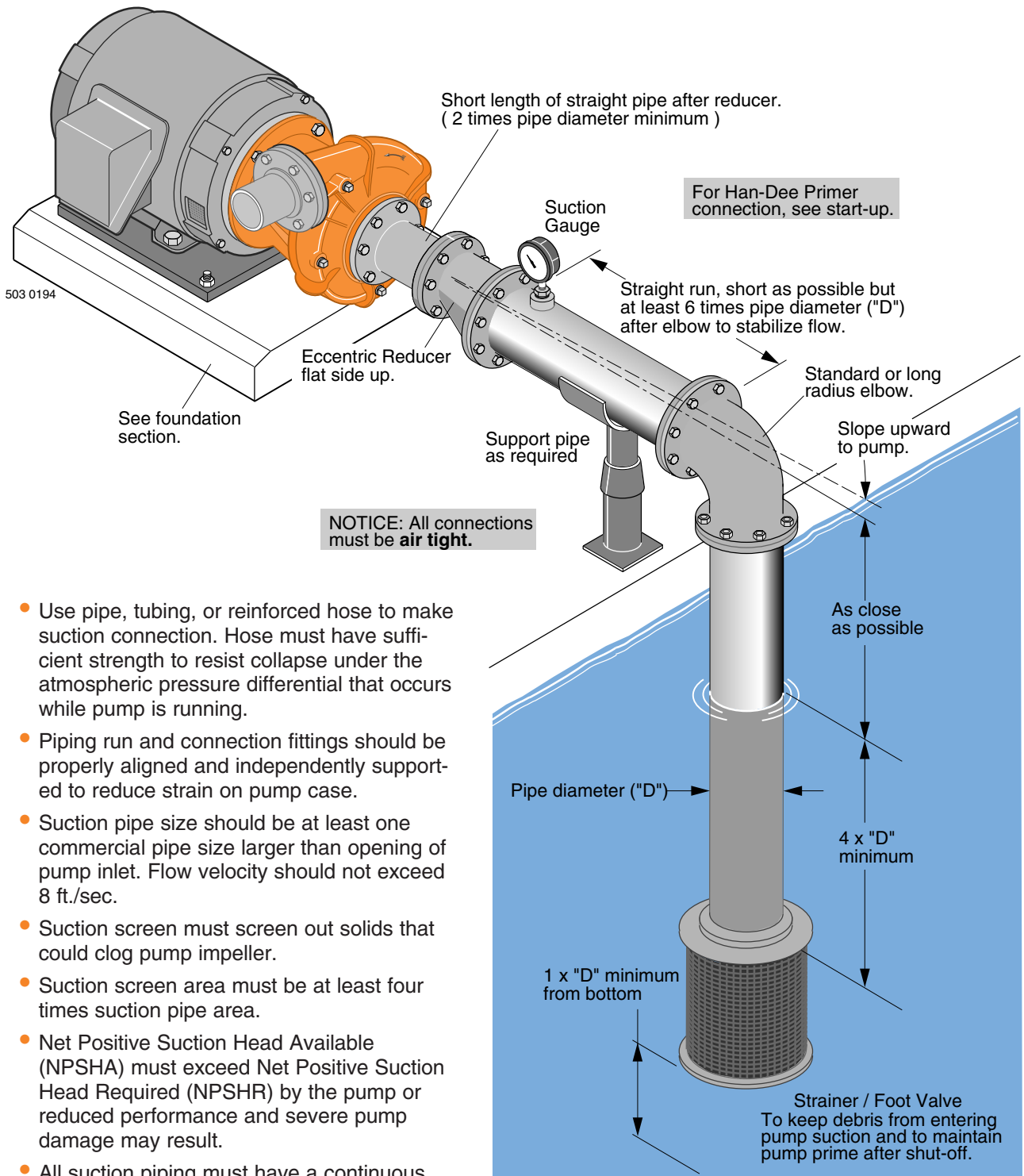

- Use pipe, tubing, or reinforced hose to make suction connection. Hose must have sufficient strength to resist collapse under the atmospheric pressure differential that occurs while pump is running.
- Piping run and connection fittings should be properly aligned and independently supported to reduce strain on pump case.
- Suction pipe size should be at least one commercial pipe size larger than opening of pump inlet. Flow velocity should not exceed 8 ft./sec.
- Suction screen must screen out solids that could clog pump impeller.
- Suction screen area must be at least four times suction pipe area.
- Net Positive Suction Head Available (NPSHA) must exceed Net Positive Suction Head Required (NPSHR) by the pump or reduced performance and severe pump damage may result.
- All suction piping must have a continuous rise to the pump suction inlet. A 1/4 inch per foot minimum slope is recommended.

Recommended

INSTALLATION

Suction Connection

Suction Lift

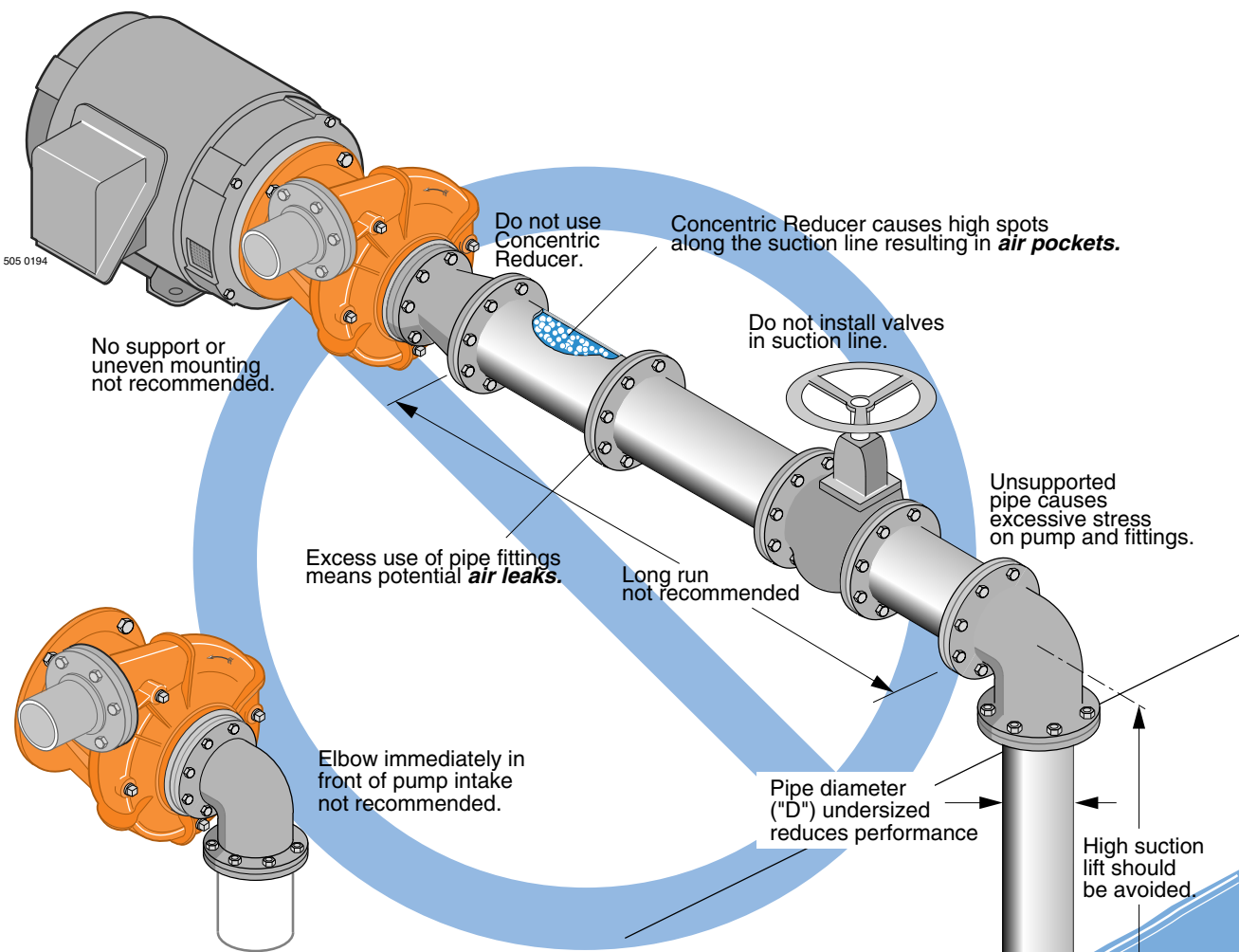

- Suction pipe sloping downward to pump inlet will trap air which will reduce performance and may cause pump to lose prime.
- Suction piping that is undersized will create excess friction losses that may cause cavitation and a reduction in pump performance.
- Excess fittings and bends in suction line results in trapped air, reduced performance, and high friction losses which may cause cavitation.

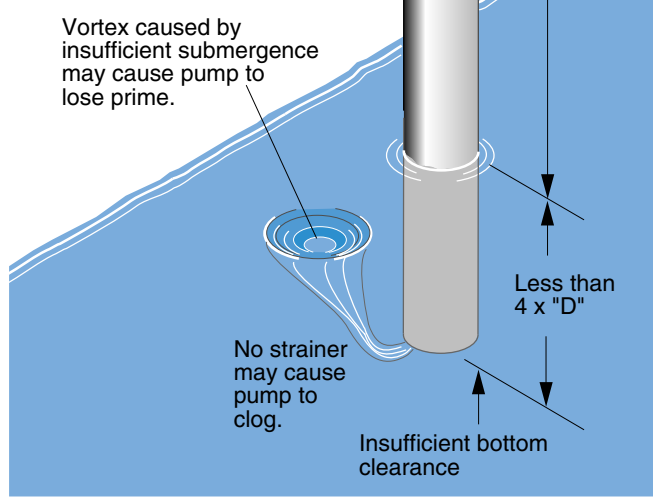

 **NOT Recommended** 

INSTALLATION

Suction Connection

When flooded suction exists

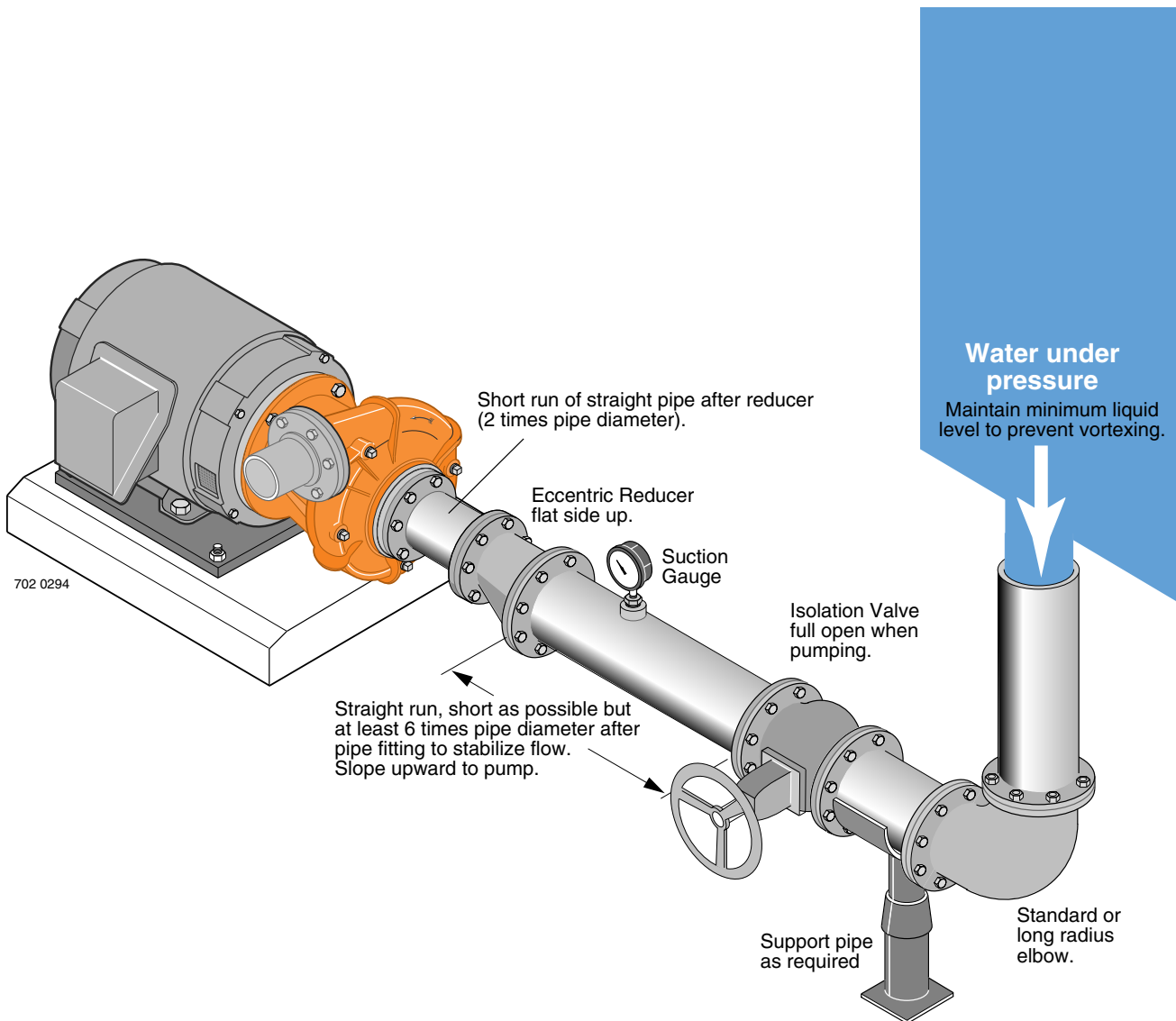

- Use pipe, tubing, or reinforced hose to make suction connection. Hose must have sufficient strength to resist collapse under the atmospheric pressure differential that may occur while pump is running.
- It is important, even with a flooded suction condition, that proper pipe fittings are used so water is delivered to impeller eye with a smooth flow and constant velocity.
- Suction pipe size should be at least one commercial pipe size larger than opening of pump inlet. Flow velocity should not exceed 8 ft./sec.

- An isolation valve is used in a pressurized suction pipe to permit servicing pump.
- Piping run and connection fittings should be properly aligned and independently supported to reduce strain on pump case.
- If solids are present, a strainer should be used to protect the pump.

Recommended

INSTALLATION

Suction Connection

When flooded suction exists

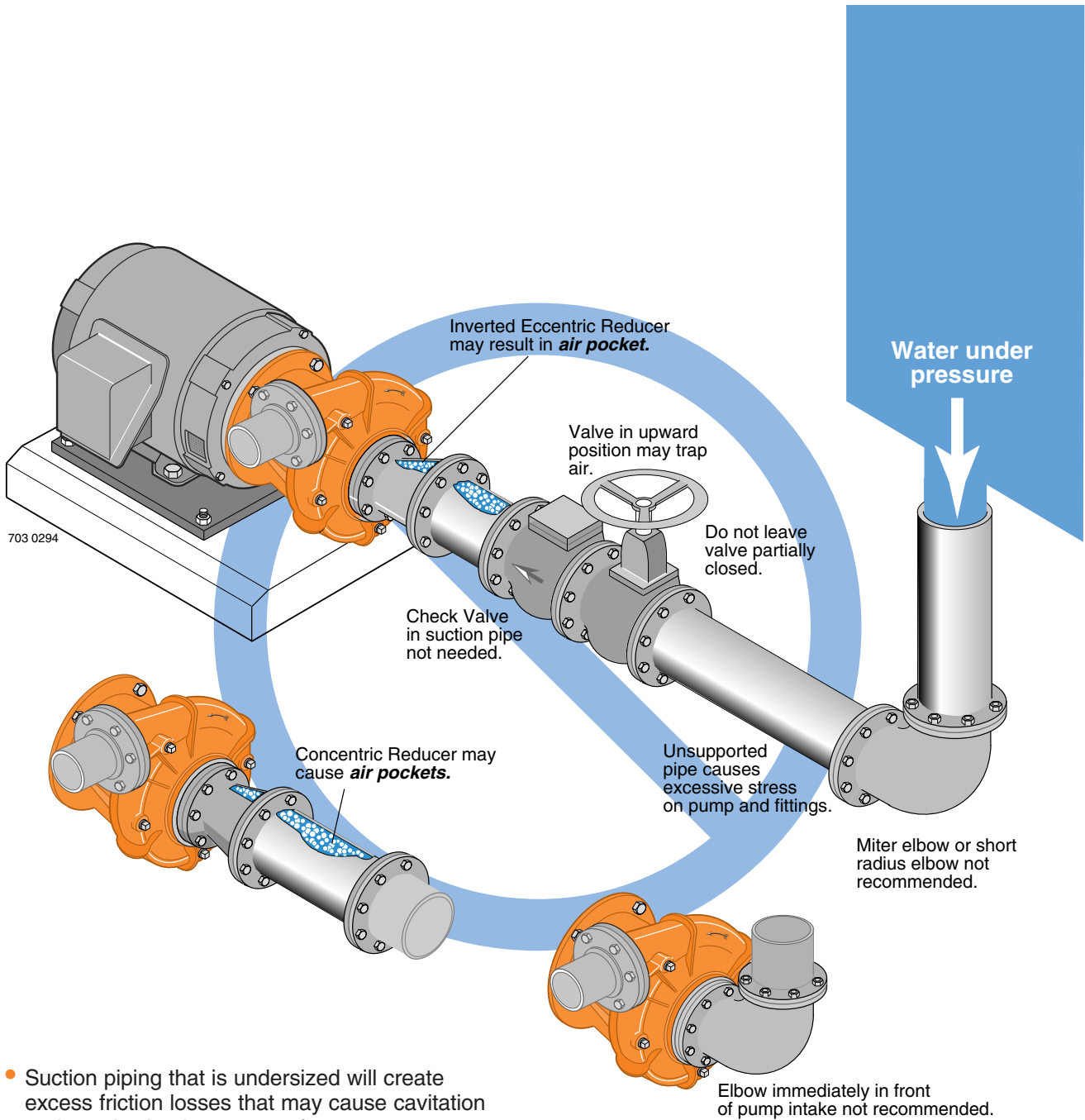

- Suction piping that is undersized will create excess friction losses that may cause cavitation and a reduction in pump performance.
- Excess fittings and bends in suction line results in trapped air, reduced performance and high friction losses which may cause cavitation.
- If a check valve is required for back flow prevention, locate on the discharge side of pump.



NOT Recommended



INSTALLATION

Discharge Connection

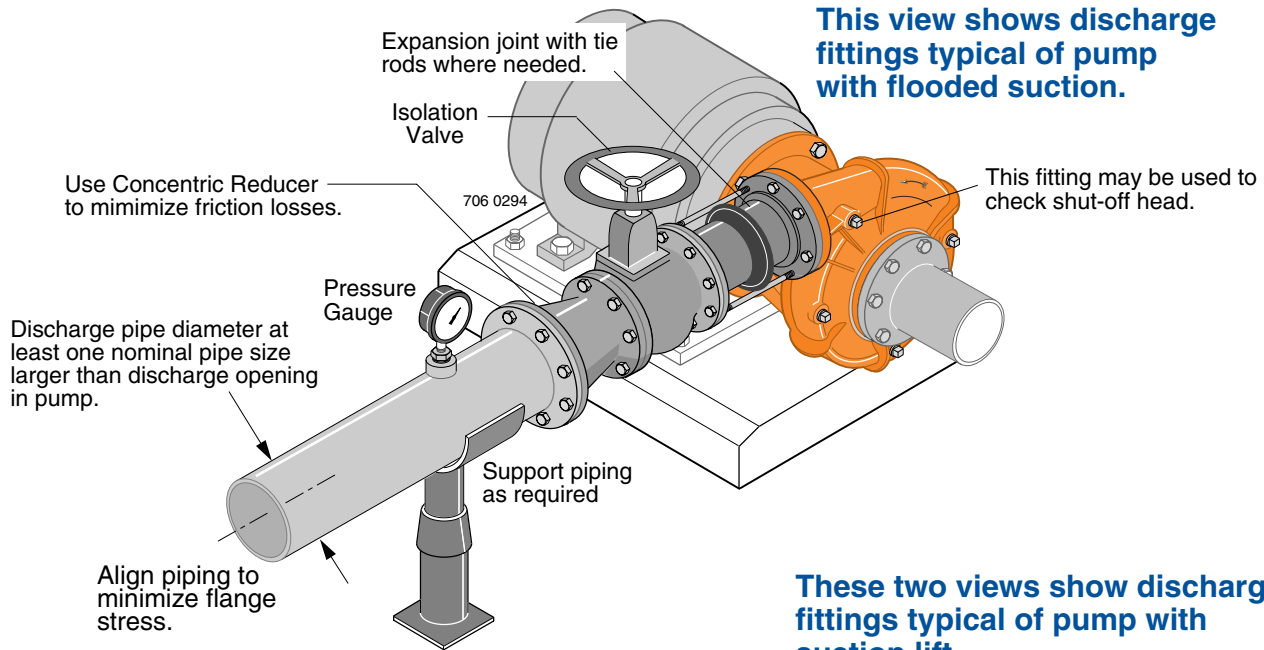

These two views show discharge fittings typical of pump with suction lift.

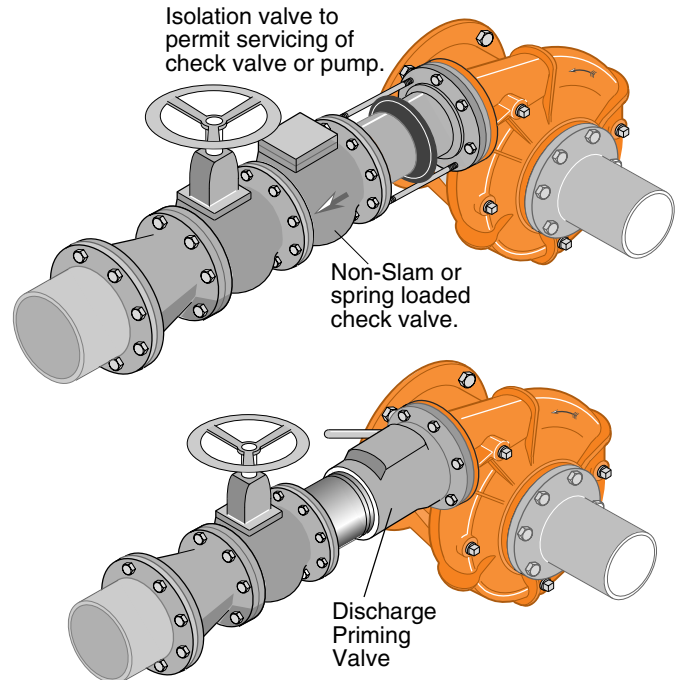

- Use pipe, tubing, or reinforced hose to make discharge connection. Material selected must have sufficient strength for operating pressures.
- Discharge pipe should be sized so that flow velocity is below 8 ft./sec.
- Use only non-slamming check valves to prevent hydraulic shock (water hammer).
- Use gate, ball, or butterfly valve for isolation. Valve should be full open during operation.
- Maintain proper pipe size throughout discharge system, using as few elbows and tees as possible to keep friction loss to a minimum.
- Install pressure gauge after reducer as shown to check operating pressure.

Recommended

INSTALLATION

Discharge Connection

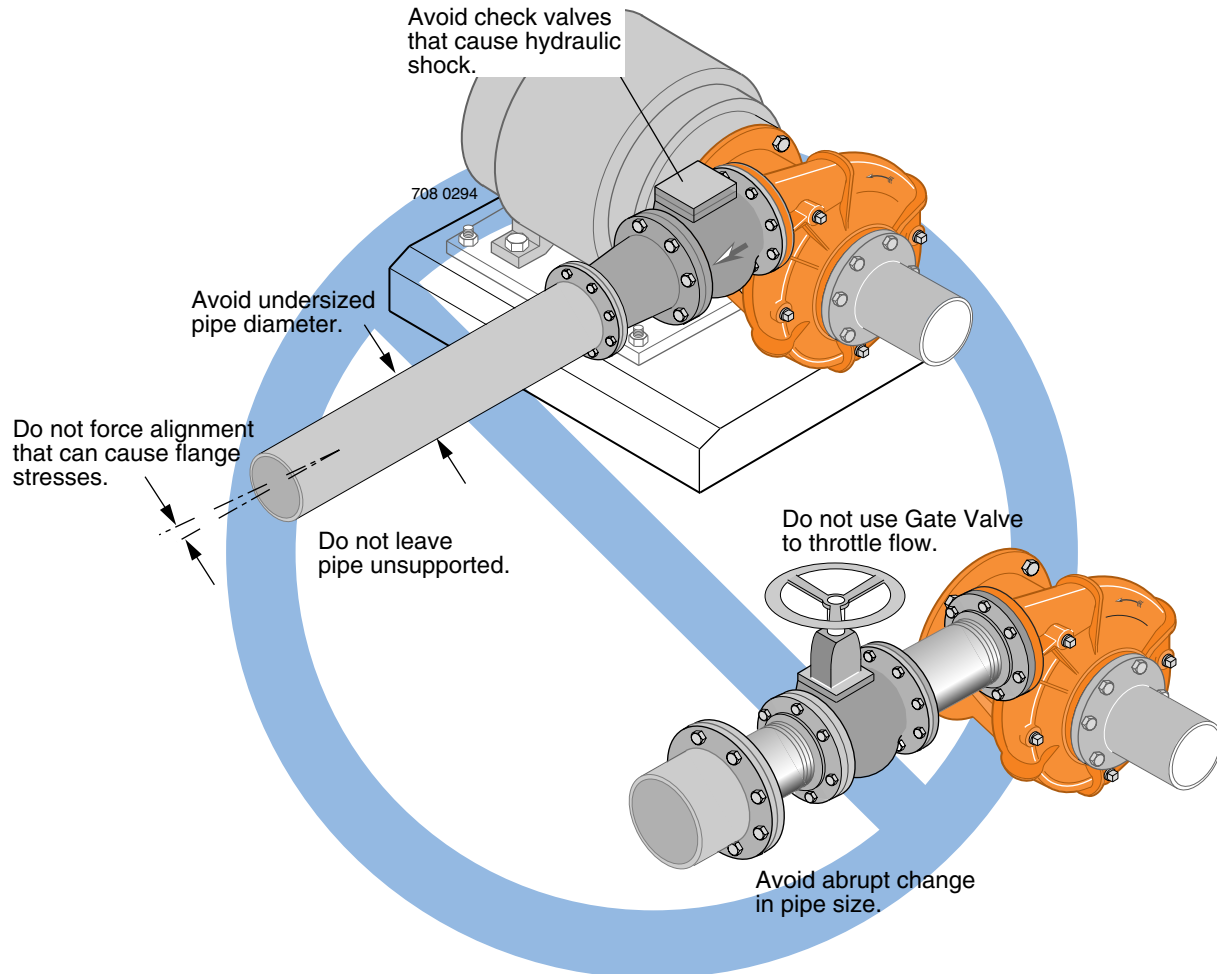

- Avoid excess friction loss caused by numerous fittings, insufficient pipe diameter, and sharp turns in pipe run.

- Some swing type check valves may permit build-up of reverse velocity before closing causing hydraulic shock or “water hammer”.



NOT Recommended



INSTALLATION

Pump Foundation

Typical Installations

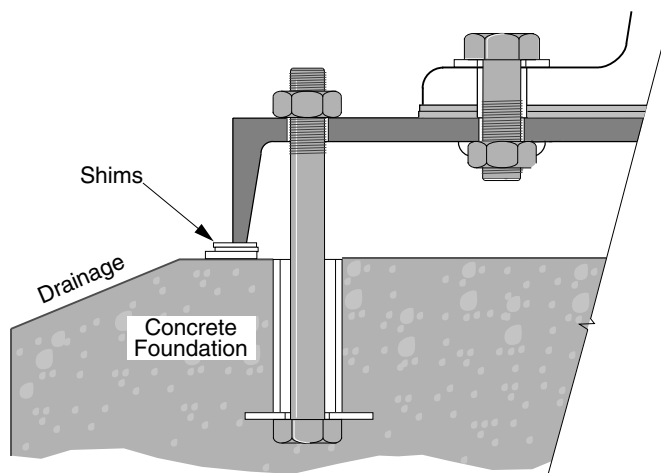
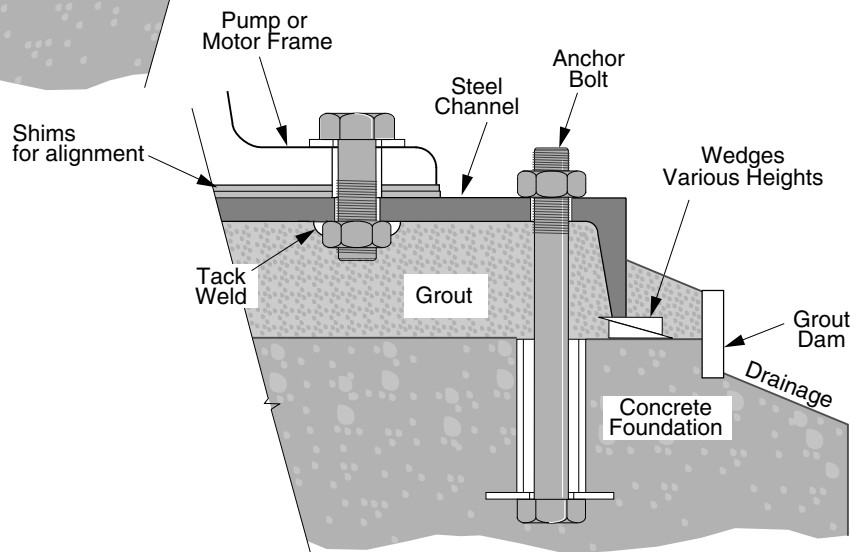
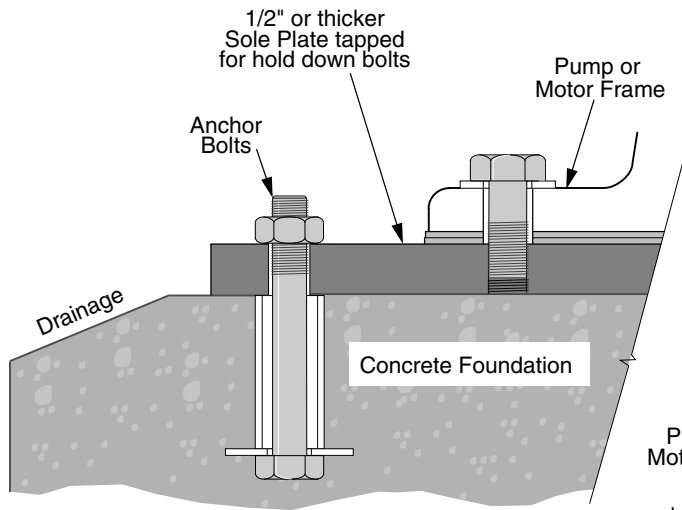

- There are several types of permanent pump/foundation installations in use. Those pictured above are typical.
- If grout is used, top of concrete should be left rough to provide a good bonding surface.
- Foundation should slope away from pump to prevent liquid from pooling.

797 0394

INSTALLATION

Pump Protection

Pump House

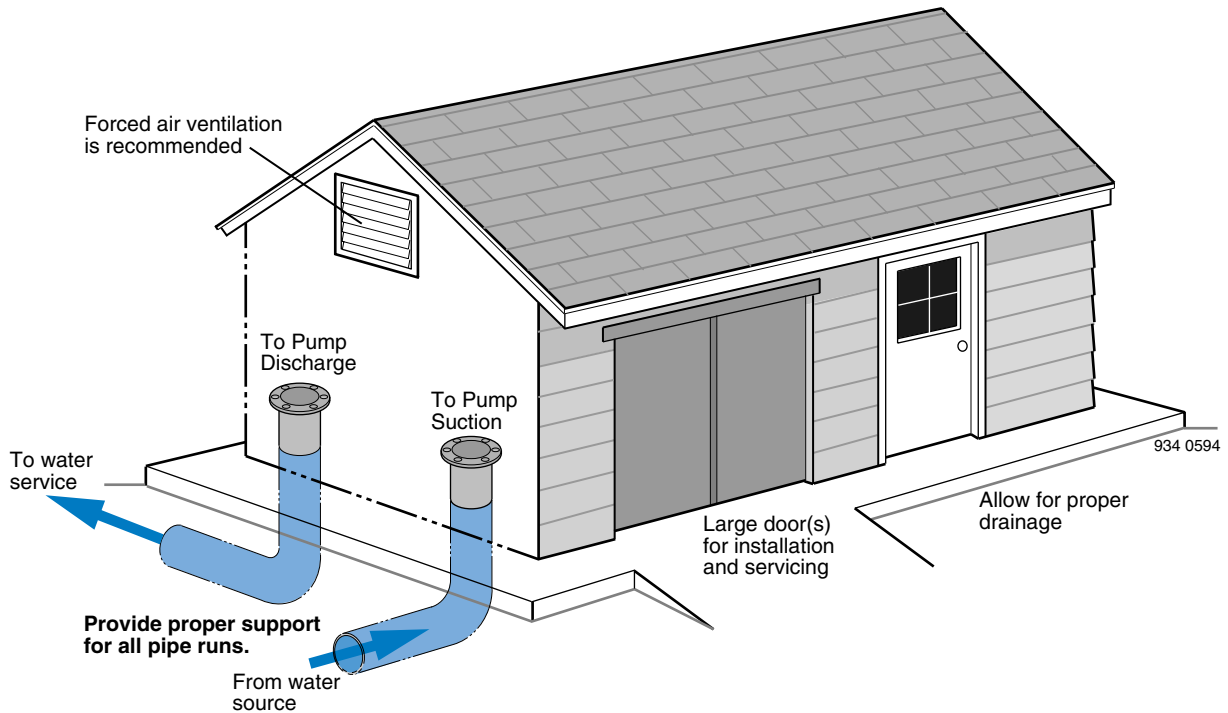

- Check local codes for all electrical connections.
- Check local codes for all plumbing connections.
- Allow adequate room around pump for servicing.
- Allow for water drainage inside pump house (floor drains).
- Allow for heating capabilities if pump is running year round.

Pump Shelter

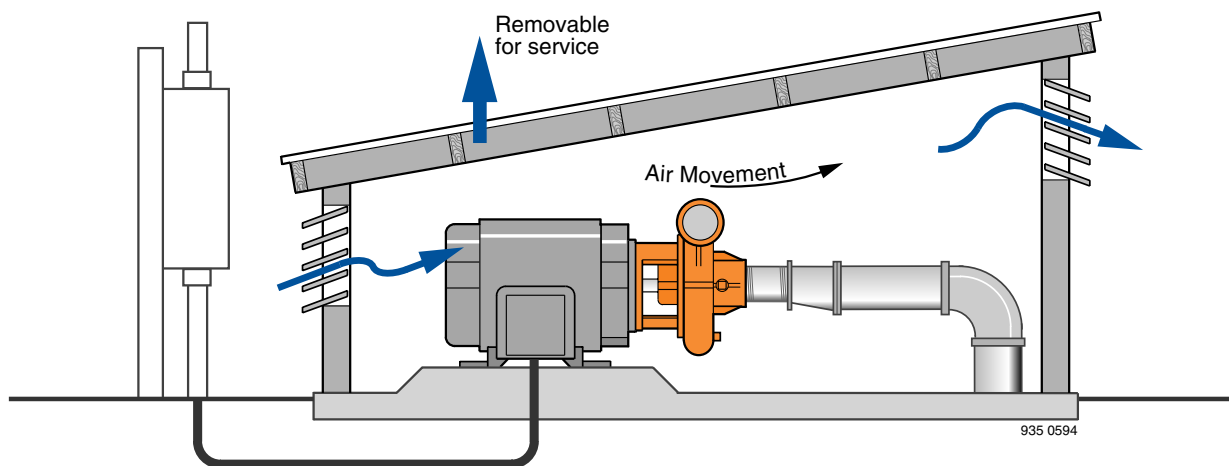

- Pump shelter with removable roof protects pump from rain, dust, plants, and the sun. Locate shelter to avoid flooding.
- Proper ventilation is a must.
- Allow for proper drainage away from pump and motor.
- Check local codes for all electrical connections.
- Check local codes for all plumbing connections.

INSTALLATION

Shaft Alignment

Coupling Alignment

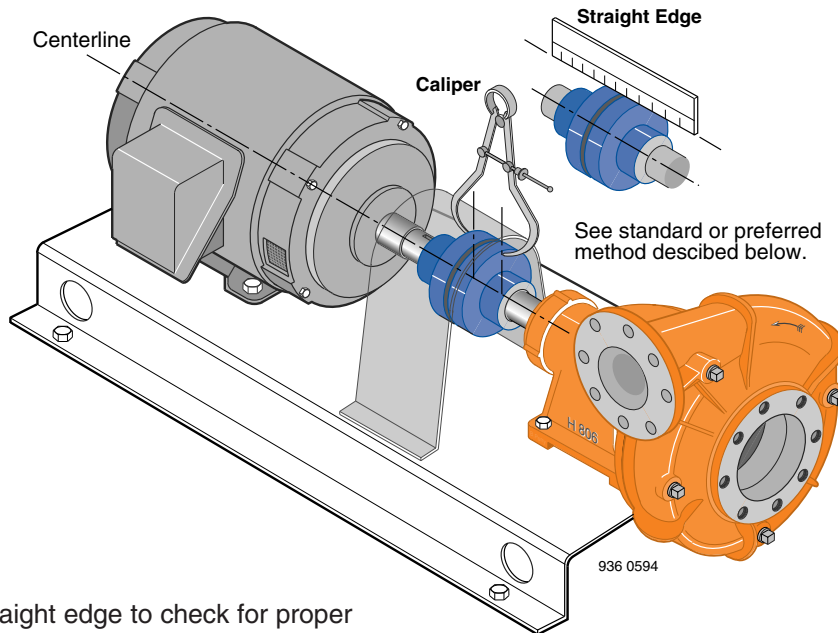

- **Standard Method:**

Use a caliper or straight edge to check for proper alignment. Check four places, 90 degrees apart.

- **Preferred Method:**

Use a commercially available dial indicator to check for proper alignment. Refer to coupling I.O.M. for detailed instruction.

- Coupling guard shown in phantom for pictorial clarity. **Never** operate pump without guard or shroud in place.

Belt Drive

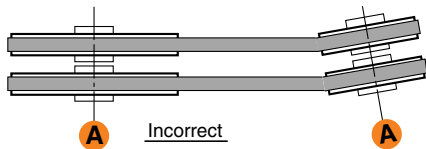

Centerline - A of each shaft and pulley must be parallel for proper alignment.

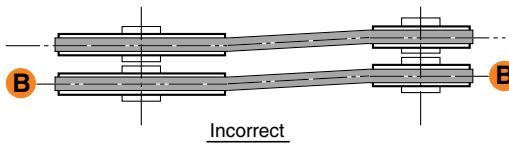

Centerline - B represents center of belt and pulley. This centerline must be straight for proper alignment.

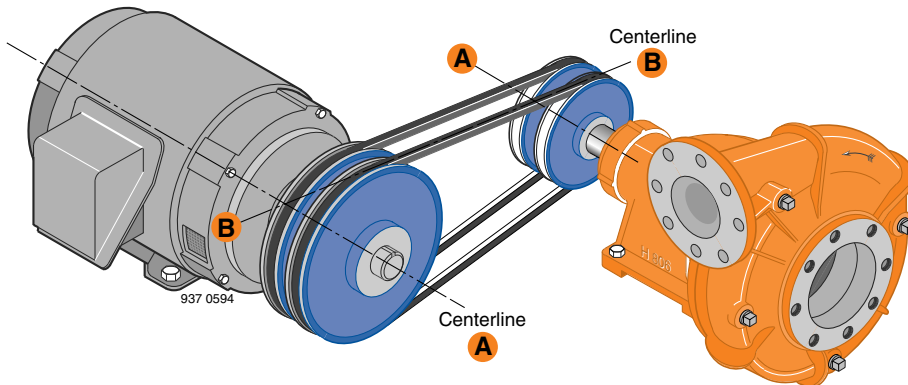

- Belt guard is not shown for pictorial clarity. **Never** operate pump without proper guard or shroud in place.

- For proper **belt tension**, check belt **manufacturer's specifications**.

INSTALLATION

Protect Your Investment

Electrical

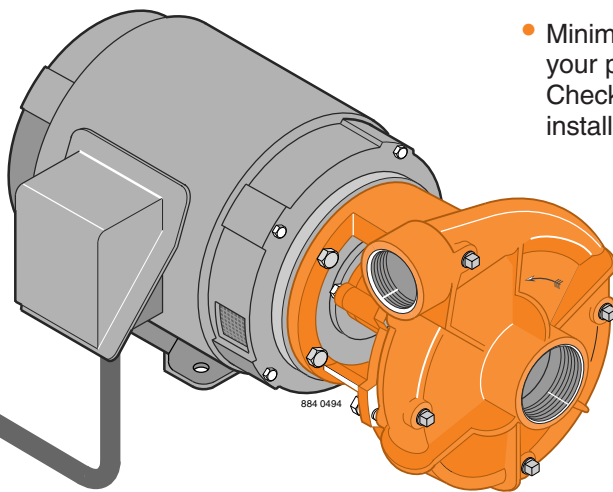
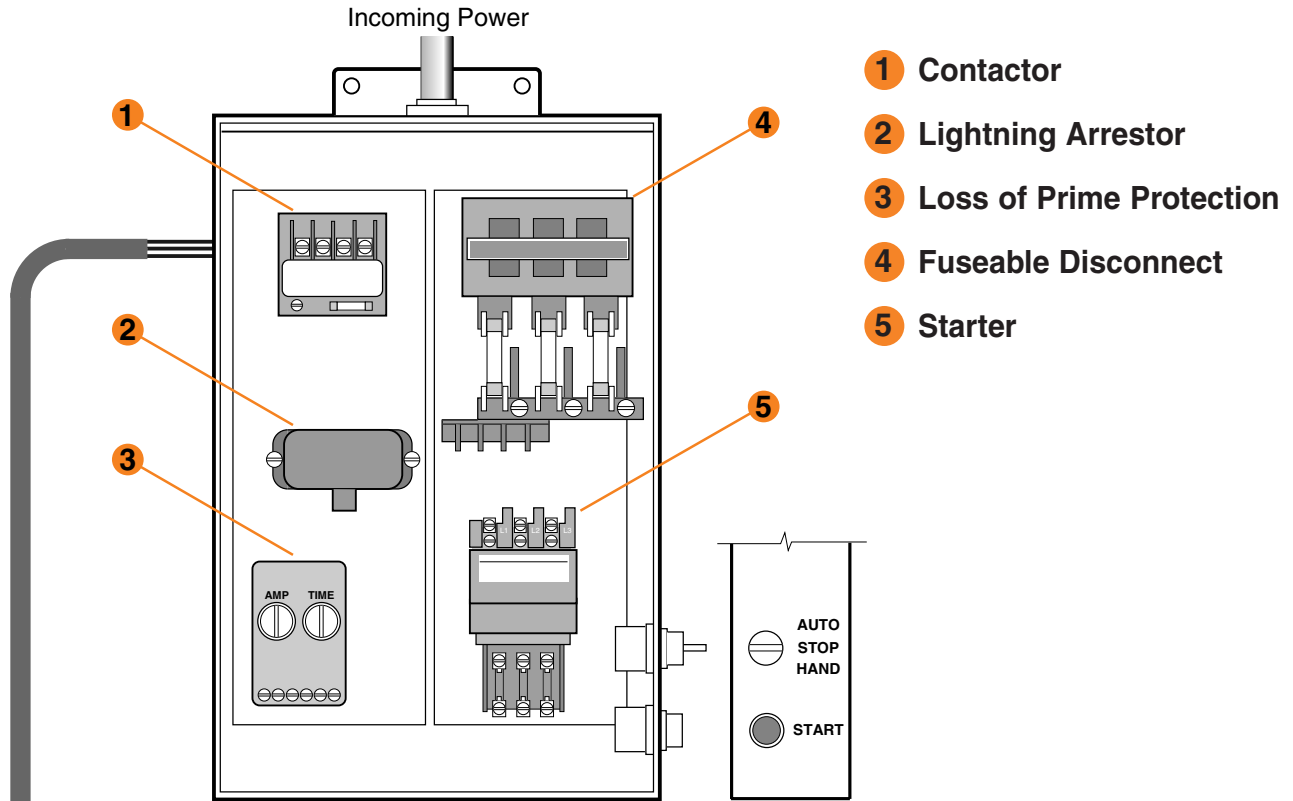

- Minimum recommended components to protect your pump during operation are listed above. Check all local electrical codes prior to installation.

INSTALLATION

Protect Your Investment

Typical Installation

Misalignment Sensing Probe and Switch for Centrifugal Pumps

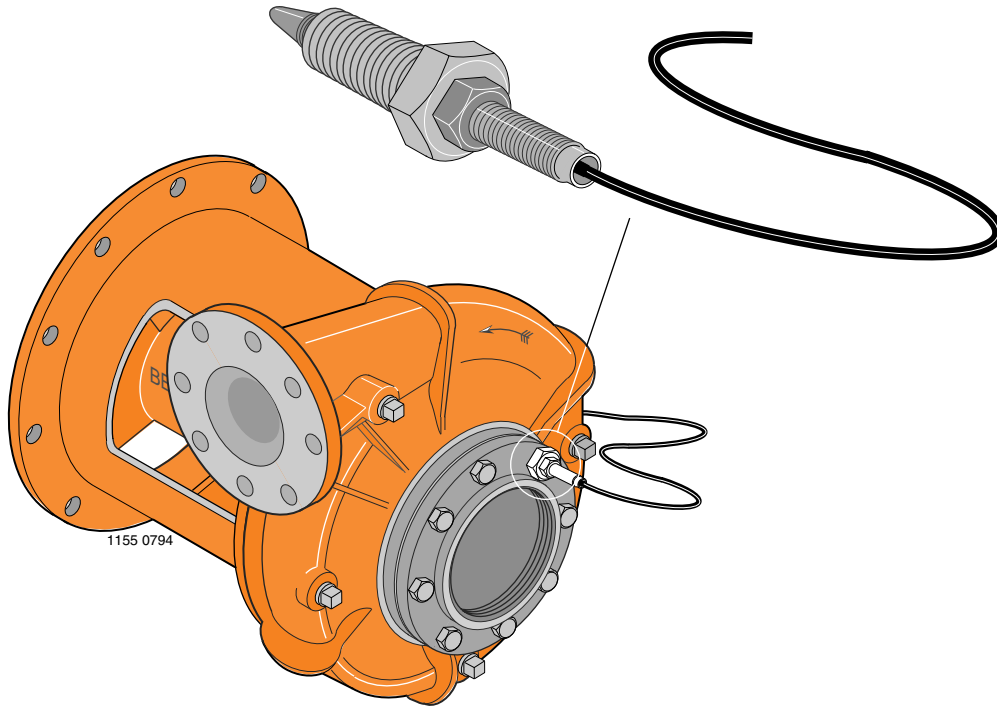

- This probe is designed to minimize damage if thrust bearing wear or impeller separation threaten your pump. When installed and adjusted properly, the probe senses slight axial movement of the rotating impeller. Unsafe movement abrades the tip of the probe, completing a circuit to shut down the power source (diesel or gas engine, or electric motor).

This protective probe circuit can also be configured to include a visual or audible warning device.

SECTION 2

Start-up

Contents

	Page
● Pump Priming.....	16,17
● Determine Pump Rotation	18
● Start-up Check List.....	19

START-UP

Pump Priming

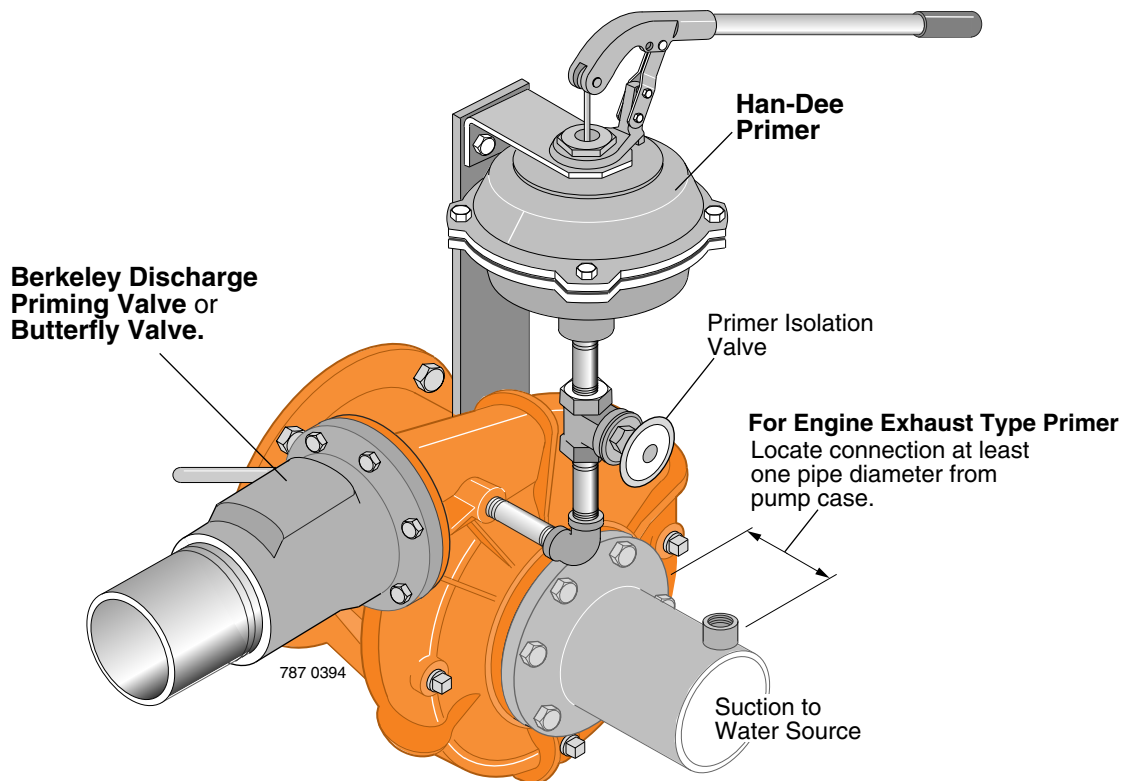

Suction Lift with Priming Pump

- Close air tight valve on discharge.
- Han-Dee Primer operation:
 1. Open Han-Dee Primer isolation valve.
 2. Work handle of Han-Dee primer up and down to evacuate air from the suction line. (Refer to primer owner's manual for proper procedure).
 3. When water flows freely from primer, close Han-Dee Primer isolation valve. (Pump case should now be filled with water).
- Immediately start pump.
- Slowly open butterfly valve (if used) until desired flow is achieved. (Discharge Priming Valve will open automatically).

Suction Lift with Engine Exhaust Primer

- Locate exhaust primer connection as shown above.
- For operation, refer to specific instructions included with exhaust primer.

START-UP

Pump Priming

Hydraulically Balanced Pumps

- Hydraulically balanced pumps operate with a very low positive pressure across the stuffing box, permitting a much looser fit of the packing rings around the shaft sleeve to control the loss of water from the pump through the stuffing box. Because of the looser fit of the packing rings, air can be more easily drawn into the pump through the stuffing box when priming the pump with an air evacuation type primer.
- A grease fitting, communicating through the side of the stuffing box to a lantern ring in the packing set, is provided to grease seal the stuffing box to prevent air leakage during priming.
- If pump cannot be primed due to air leakage through the stuffing box, **DO NOT** tighten packing. Instead, pump grease into fitting until back pressure occurs, forcing grease into lantern ring to seal the stuffing box. After priming, when unit is put into operation, the grease will be flushed out through the packing by water flowing outward through the stuffing box. Proceed with normal adjustment of the packing as described in pump owners manual. Note that the grease seal is used **only** for control of air leakage during priming, and that **only** the packing gland is used to control the flow of water through the stuffing box during normal operation.

Suction Lift with Foot Valve

- Close air tight valve on discharge.
- Remove pipe plug from highest opening in pump case.
- Completely fill pump and suction piping with water.
- Rotate shaft slowly to allow any air trapped in impeller to escape.
- When all air has been forced out of pump, replace pipe plug. Use pipe joint compound on plug threads and tighten as necessary to prevent leakage.

Flooded Suction

- Close air tight valve on discharge.
- Open air vent (or pipe plug) in the highest tapped opening in pump case.
- Open inlet isolation valve, allowing water to fill the pump completely and force all air out through vent.
- Rotate shaft slowly to allow any air trapped in impeller to escape.
- Close vent opening when water without air emerges.

START-UP

Determine Pump Rotation

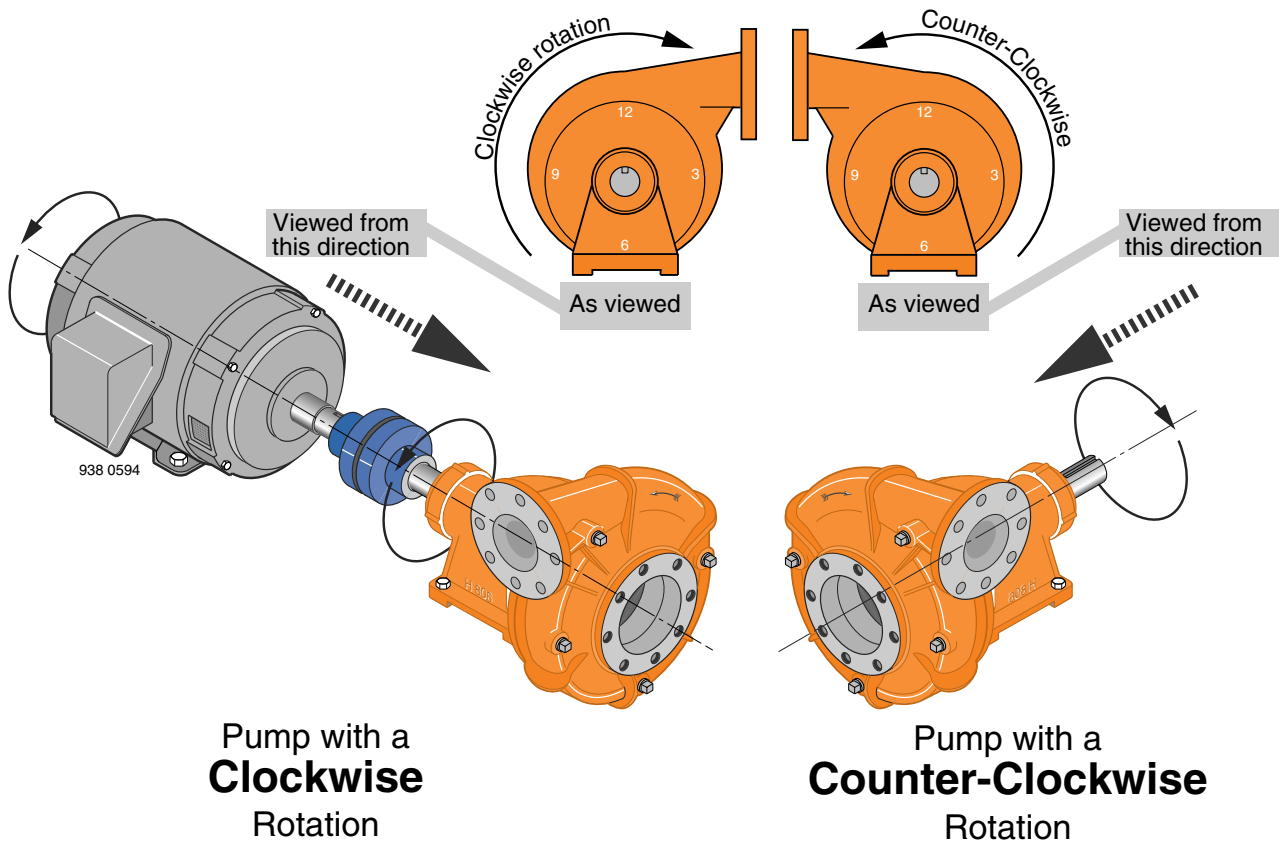

Pump Rotation is determined as clockwise or counter-clockwise by viewing liquid end of pump from the **back** or **shaft side**, and **NOT** from looking into the impeller eye or front of volute.

Pump Rotation **must** be verified after installation.

- **Electric Motors:**

Single Phase: Refer to wiring information on the motor plate to obtain proper rotation.

Three Phase: If pump runs backward, reverse any two leads coming off incoming power (L1, L2, L3) until proper rotation is obtained. (ie: reverse L1 and L2, L2 and L3, or L1 and L3).

- **Note:** It is common for many motor and engine manufacturers to indicate rotational direction in the opposite manner as the pump standard. That is, they refer to the rotation as viewed from the front of motor or engine. **Pump** rotation is determined by viewing from the **back**.
- Pump running backward – A centrifugal pump will still pump liquids, however, GPM and head will be a fraction of the published performance.

START-UP

Check List

- Read and be familiar with the pump Installation, Operation and Maintenance Manual. Check to see that all aspects of these instructions have been complied with.
- Pipe connections must be securely fastened and air tight. All piping must be clean and free of debris.
- Is pump and all piping properly supported and are all supports securely fastened?
- Are required screens in place?
- Are all valves in the system in the proper open or close position for start-up?
- Confirm power source voltage matches the motor nameplate.
- Verify that belt or coupling alignment is properly adjusted if applicable, and that all safety guards are in place.
- Does the impeller / shaft rotate freely?
- Is pump primed?
- Verify that rotational direction is correct for pump by **VERY** short “on-off” of power source.
- Slowly open discharge valve to obtain desired flow rate of pumping system.



WARNING

Do not start pump until above checks have been made and all start-up instructions in the pump I.O.M. have been complied with. Failure to do so may result in severe damage to equipment, cause personal injury, and may void warranty.

SECTION 3

Maintenance

Contents

	Page
● Impeller Replacement	22
● Packing Replacement	23
● Mechanical Seal Replacement – Disassembly, Motor Drive	24
● Mechanical Seal Replacement – Reassembly, Motor Drive	25
● Routine Maintenance	26,27
● Recommended Spare Parts	28
● Winterizing	28

MAINTENANCE

Impeller Replacement

Threaded Shaft – Frame Mount

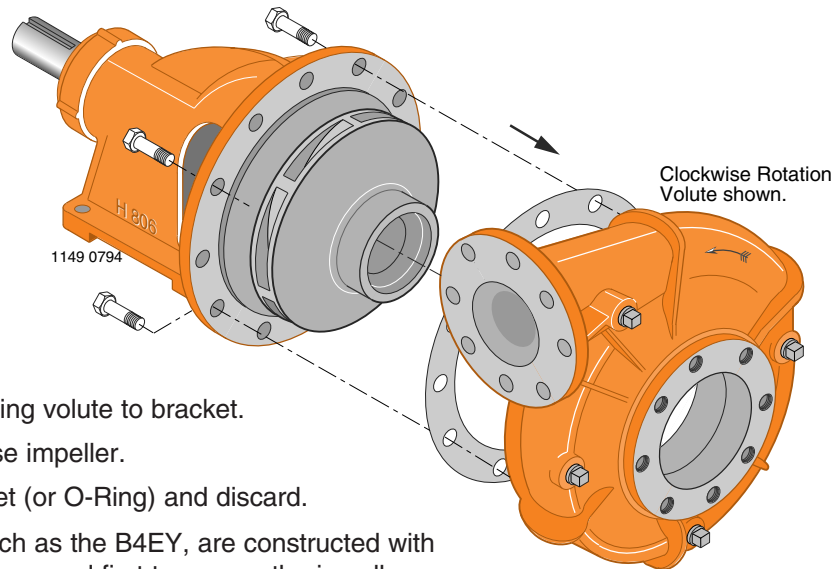

1

- Unfasten hardware holding volute to bracket.
- Remove volute to expose impeller.
- Peel off old volute gasket (or O-Ring) and discard.

NOTE: Certain models such as the B4EY, are constructed with a suction flange which is removed first to access the impeller.

Clockwise rotation as viewed from shaft end.

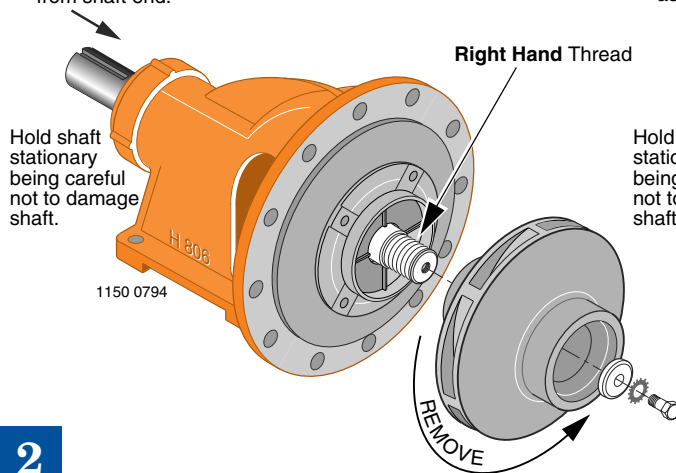

Counter-Clockwise rotation as viewed from shaft end.

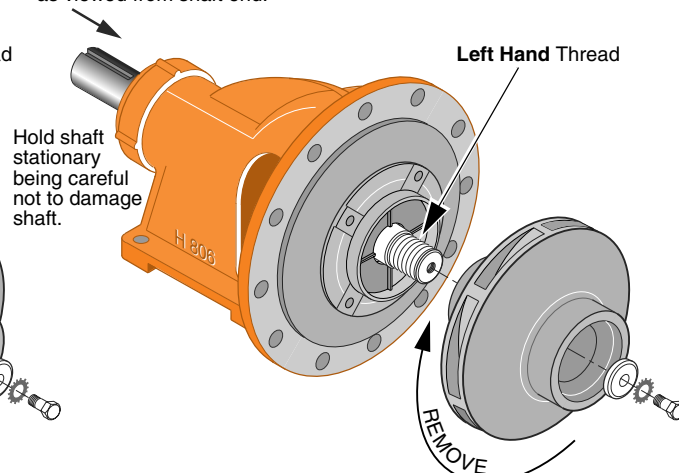

2

- Hold impeller stationary and remove impeller screw and associated hardware.
- Hold shaft stationary and remove impeller by turn-

ing in the direction shown for either clockwise or counter-clockwise pump rotation.

NOTE: Do not use impeller vanes for leverage.

Keyed Shaft

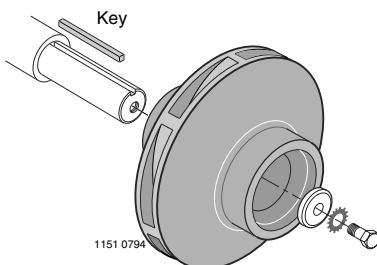

- If motor drive with keyed shaft, refer to mechanical seal disassembly drawing.
- For bearing frame pumps with keyed shaft, consult with factory for approved method of impeller removal.

MAINTENANCE

Packing Ring Replacement

Removal

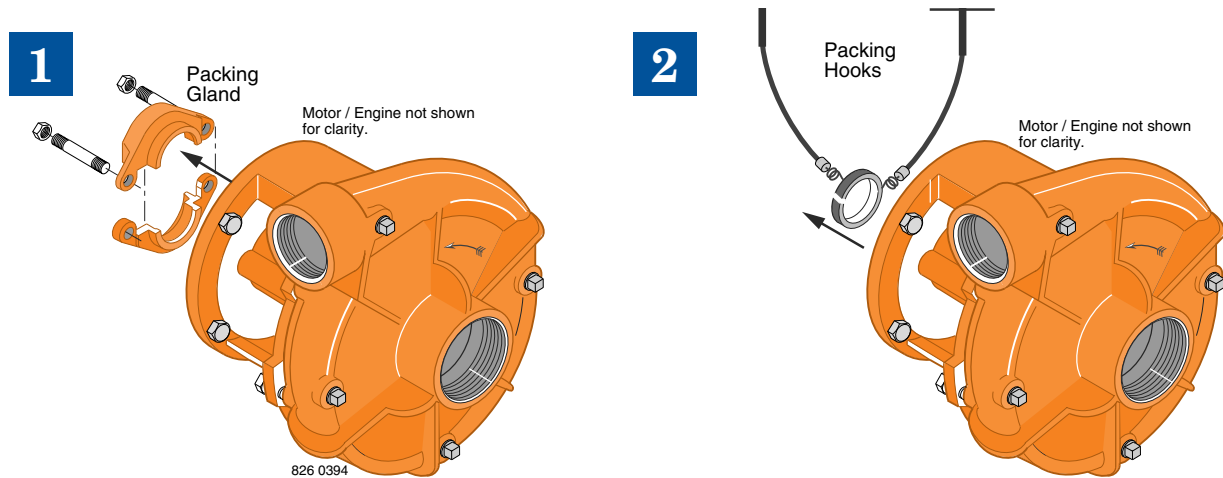

- Unfasten hardware holding Packing Gland in place and slide back on shaft to expose packing rings. A split Packing Gland with threaded studs is shown.
- Remove packing rings from stuffing box using two commercially available Packing Hooks as shown.
- Slide Lantern Ring (if used) back to expose any remaining rings, including metallic. Remove them in the same manner.

Installing New Rings

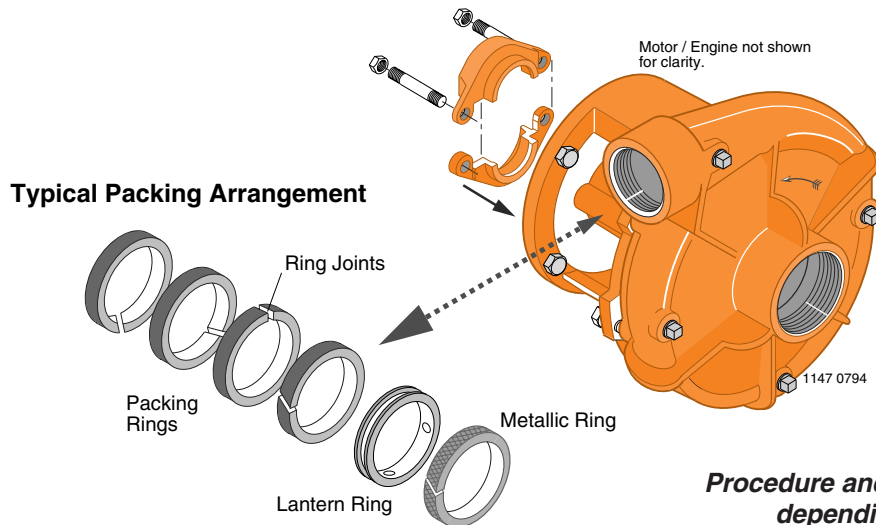

Procedure and parts will vary slightly depending on pump style.

- Clean shaft sleeve and Packing Gland.
- Inspect shaft sleeve for wear, replace if needed.
- Install new packing rings in stuffing box by placing over shaft sleeve and pushing them in as far as they will go.
- Rotate ring joint 90 degrees when installing each ring as shown.
- Slide packing gland into position, then gently and evenly tighten nuts to force rings into place and seat (do not overtighten). Loosen nuts again to hand tight.
- Start primed pump and allow packing to leak liberally.
- Evenly tighten gland nuts one complete turn at a time until leakage is reduced to 40 to 60 drops per minute.

MAINTENANCE

Mechanical Seal Replacement

Disassembly – Motor Drive



1

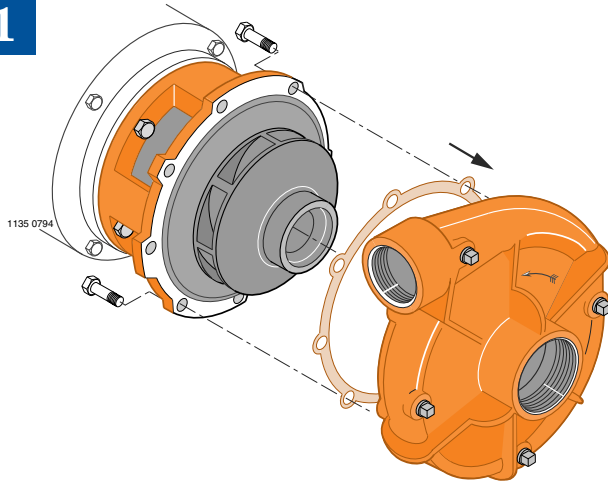

- Unfasten hardware holding volute to bracket.
NOTE: For model B4EY, consult factory for special instructions.
- Remove volute case to expose impeller.

2

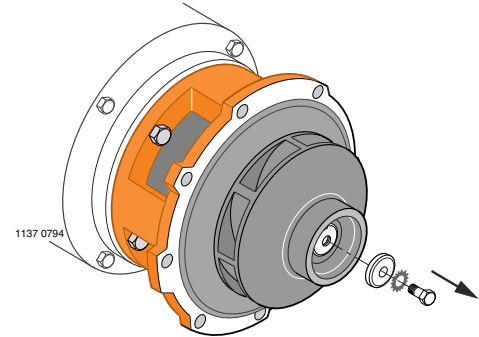

- Peel off old gasket or O-Ring and discard.
- Hold impeller stationary and remove impeller screw and associated hardware.

Procedure and parts will vary slightly depending on pump style.

3

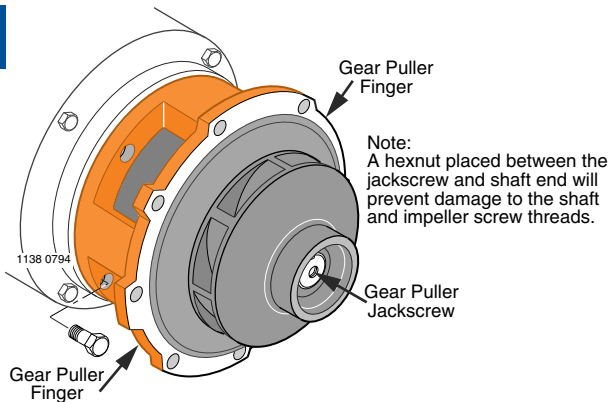

- Remove capscrews holding bracket to motor.
- Install a standard gear puller to shaft end and motor bracket placing puller fingers in the area shown.
- Rotate gear puller jackscrew until impeller clears

4

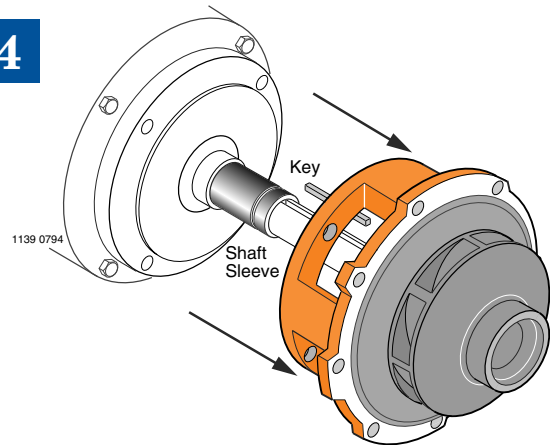

- shaft. Mechanical shaft seal will come off with motor bracket.
- If a seal retaining ring is part of the assembly, it will need to be replaced.

5

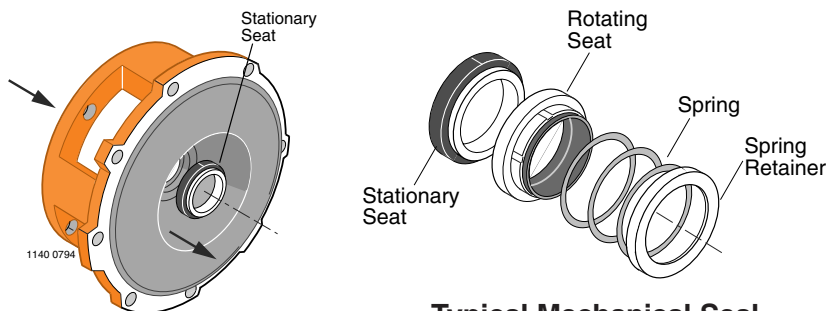

- Push stationary seat out of seal cavity from the back of bracket.
- Clean seal cavity in bracket thoroughly.

Typical Mechanical Seal

MAINTENANCE

Mechanical Seal Replacement

Reassembly – Motor Drive



1

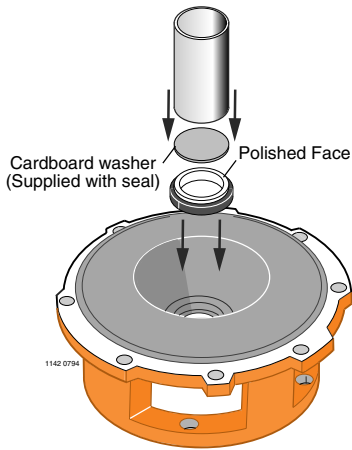

- Place bracket on a smooth, flat surface, pump side up.
- Apply a small amount of mineral oil to O-Ring on stationary seat and press into seal cavity. Cover ceramic face with cardboard washer and press

2

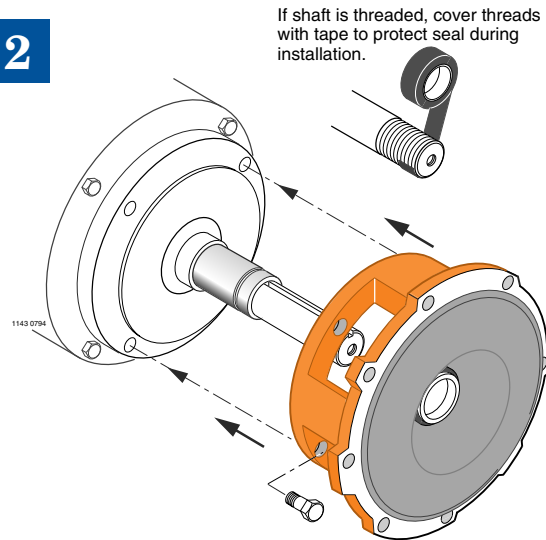

- straight in using a piece of pipe or tubing.
- Reinstall bracket on motor using extreme care not to scratch or chip ceramic face of seal with shaft.

3

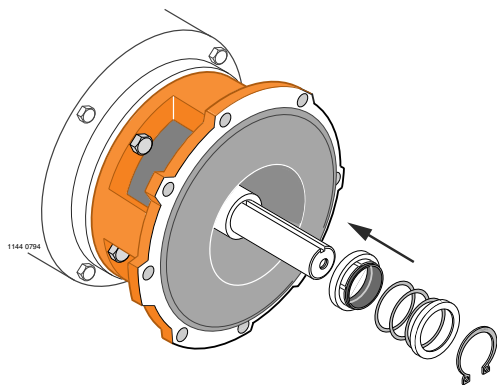

- Apply a small amount of mineral oil to inside diameter of rubber ring in rotating seat and outside of shaft sleeve. Slide rotating seat onto shaft, polished face first, until it is tight against ceramic face.
- Compress seal spring, and install retaining ring (if used) in shaft sleeve groove.

4

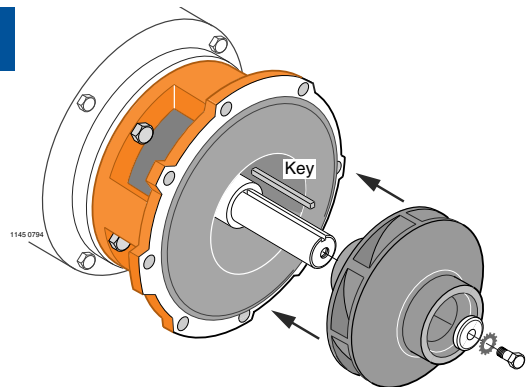

- Place impeller key in motor shaft keyway. Slide impeller on to shaft as far as possible.
- Apply non-permanent thread adhesive to impeller capscrew and shaft threads.
- Install impeller washer, shakeproof lockwasher, and capscrew.

5

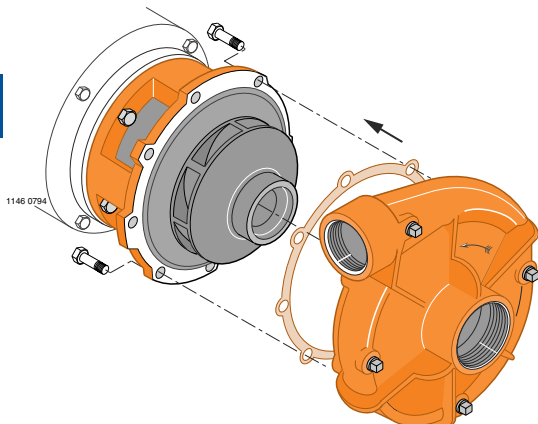

- Install new gasket or O-Ring and volute case onto bracket.
- Install new O-Ring gasket and volute case on to bracket.
- Apply anti-seizing compound to capscrews and tighten securely.

Procedure and parts will vary slightly depending on pump style.

MAINTENANCE

Routine Maintenance

A well maintained pumping system will extend the life of the unit and require fewer repairs. This means less down-time which can be very critical when a constant delivery of liquid is required.

A routine maintenance and inspection schedule should be set up on a weekly, quarterly, and annual basis with records kept of these actions. (Refer to individual pump owner's manual for required maintenance and/or lubrication).

Weekly

Observe the following to verify that pump unit is operating properly.

- **Vibration** – All rotating machines can be expected to produce some vibration. However, excessive vibration can reduce the life of the unit. If the vibration seems excessive, discontinue operation, determine cause, and correct.
- **Noise** – When the unit is operating under load, listen closely for unusual sounds that might indicate that unit is in distress. Determine the cause and correct.
- **Operating Temperature** – During operation, heat is dissipated from the pump bearings and the driver. After a short period of time, the surface of the pump bracket will be quite warm (as high as 150°F), which is normal. If the surface temperature of the pump bracket or driver is excessive, discontinue operation, determine cause of the temperature rise, and correct. Bearings will run hotter for a brief run-in period after packing which is normal. However, worn bearings will cause excessive temperatures and need to be replaced.

The pump unit is cooled by the water flowing through it, and will normally be at the temperature of the pumping liquid.

- **Stuffing Box** – After a short period of operation, verify that the stuffing box area and gland are not hot. If heating is detected, loosen the gland nuts evenly until water is just running out of stuffing box in a DROPLET form. Water must not be streaming or spraying out. Verify cool operation periodically. Adjust gland nuts **EVENLY** as necessary for lubrication and cooling of the packing. If packing has been tightened to the limit of the packing gland travel, additional packing is necessary.
- **Mechanical Seal** – Inspect seal for leakage. There should be no leakage at mechanical seal.
- Inspect suction line and/or screen for flow obstruction.

Quarterly

- **Pump and Piping Connections** – Inspect all system piping connections for leakage or possible misalignment. Misalignment of pipe connections to the pump will put excessive strain on the pump case and can cause damage to internal components of both the pump and motor. If stress on the pump case is suspected, adjust pipe supports to correct. For flange connections, misalignment can be checked by shutting down the pump, and removing the pipe flange bolts on the pump connections. If the mating flanges come apart or shift, there is pressure at the connection(s) and adjustments

MAINTENANCE

Routine Maintenance

should be made to the piping supports until flanges mate without force. This procedure can be done throughout piping system.

- Check pump foundation for soundness and see that all hold-down bolts are secure.
- Complete any lubrication requirements as dictated by pump/driver owners manuals.
- Inspect packing or mechanical seal for possible replacement. Examine shaft sleeve, if present, for wear and replace it if necessary.
- Inspect pumping plant panel for signs of wear (ie: replace pitted contactors, etc., as needed).
- Check pump and/or motor bearings for signs of wear. Repack or replace as required.

Annual

- Inspect pump and entire pumping system for signs of wear.
- Inspect system valves, screens, etc.
- Check electric motor windings for degradation, rewind if necessary.
- Check pump impeller eye clearance.
- Inspect impeller, volute case, and seal chamber for signs of excessive wear or corrosion.

MAINTENANCE

Spares / Winterizing

Recommended Spare Parts

The number and type of spare parts kept on hand at any pump site is dictated by the severity of the service in which the pump is used. That is, a pump servicing a golf course's sprinkling system should not be down because of a simple case gasket, or a subdivision out of water because of a failed mechanical seal.

It is recommended that the following spare parts be kept on-site as a minimum back-up to service pump and reduce down-time. Parts shown do not apply to all models. Check your model/style against parts breakdown drawing(s) when selecting spares.

- Mechanical Shaft Seal
- Packing set and packing hooks
- Shaft Sleeve(s)
- Impeller wear ring
- All gaskets and O-Rings required for one pump
- Retaining Rings

If having a pump non-operational has severe consequences, a back-up pump should be considered. Otherwise, a back-up impeller, volute case, bearings and shaft, would be prudent.

Winterizing

If pump is to be out of service for an extended period of time, such as the winter months, the following storage procedures should be followed.

- Remove exterior dirt and grime or any substance that may trap moisture. Exposed metal is subject to oxidation, prime and repaint if necessary.
- Flush suction and discharge lines. Check for leaks at this time and replace any worn gaskets.
- Remove lowest plug in pump and drain pump casing and suction and discharge lines.
- Lubricate bearings (refer to owners manual).
- If possible, keep unit clean and dry during storage period to guard against corrosion.
- Seal all open ports to keep out foreign objects such as insects, rodents, dust and dirt.
- Rotate driver shaft periodically to prevent freeze-up of internal components.
- Shelter pump from the elements when possible.

SECTION 4

Pump Nomenclature

	Page
• Nameplate Data	30
• Part Nomenclature – Electric Motor Drive.....	31
• Part Nomenclature – Bearing Frame Mount.....	32
• Part Nomenclature – S.A.E. Engine Mount	33
• Part Nomenclature – Air Cooled Engine Drive	34
• Part Nomenclature – Air Cooled Engine Drive, Self Prime	35

PUMP NOMENCLATURE

Nameplate Data

Model Number

Example: B3TPMS

- B** – Berkeley Type B Centrifugal
- 3** – Pump discharge size - 3 inch
- T** – Nominal Impeller diameter - 6 inch
- P** – Pump Type - Electric Motor Drive
- M** – Impeller capacity - Medium
- S** – Mechanical Seal

(Refer to Berkeley Catalog for model nomenclature information)

Serial Number

Example: G100894

Date code. Represents the day, month and year that the pump was built.

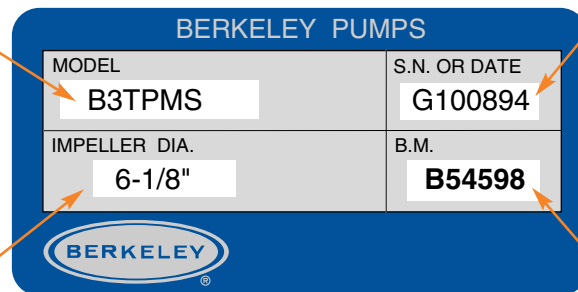

Impeller Trim

Example: 6-1/8"

Size of outside diameter of Impeller. Required when ordering replacement impeller.

Bill of Material number

Example: B54598

Also referred to as **Catalog Number**. **Use this number** when ordering repair parts or service requirements. This is the most important number on the tag for pump identification purposes.

PUMP NOMENCLATURE

Electric Motor Drive

Mechanical Seal

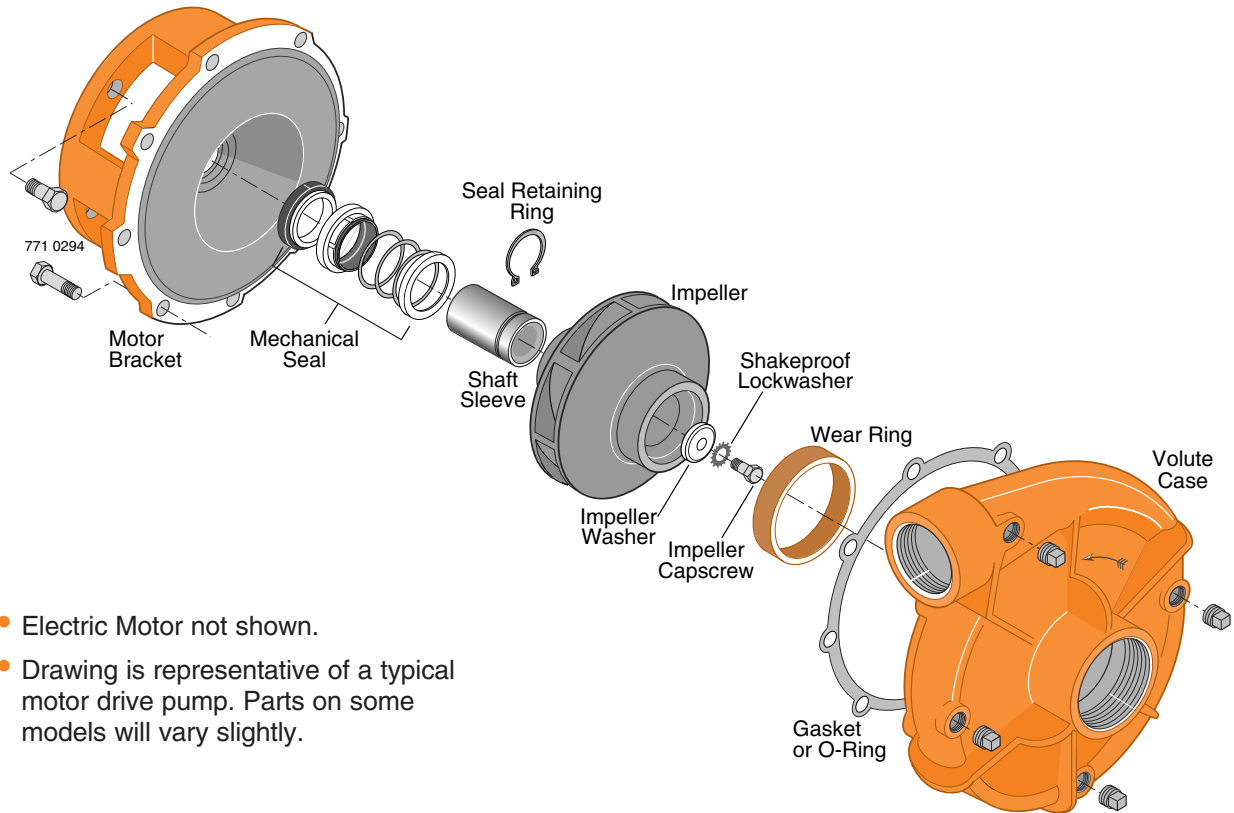

- Electric Motor not shown.
- Drawing is representative of a typical motor drive pump. Parts on some models will vary slightly.

Packing

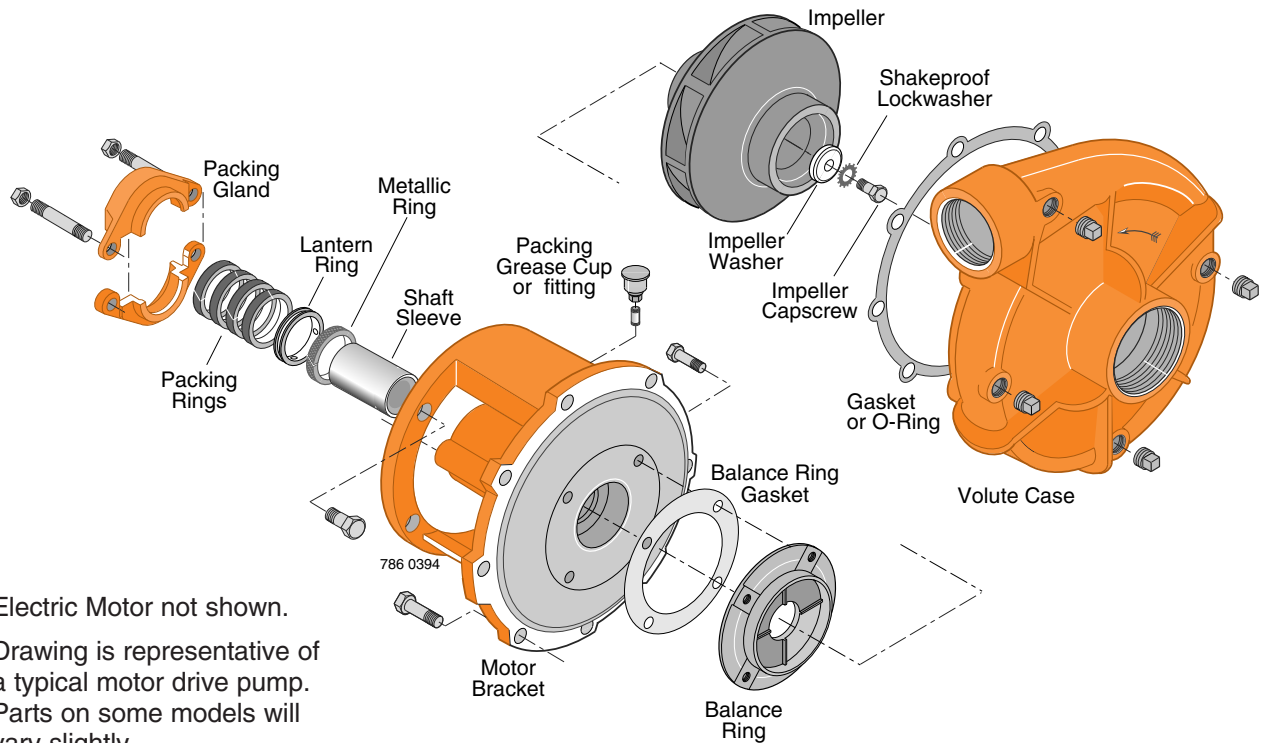

- Electric Motor not shown.
- Drawing is representative of a typical motor drive pump. Parts on some models will vary slightly.

PUMP NOMENCLATURE

Bearing Frame Mount

Packing / Mechanical Seal

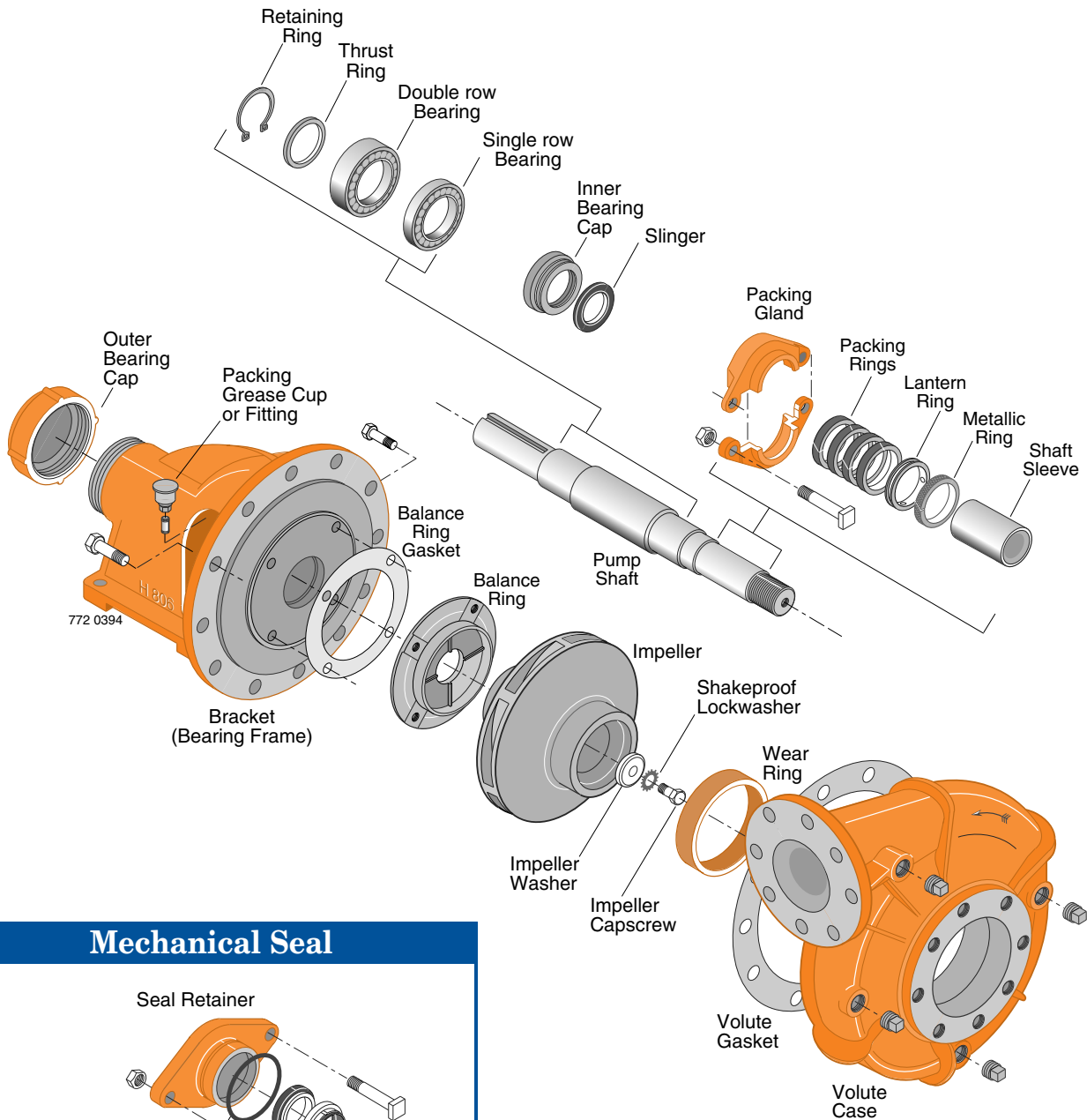

Mechanical Seal

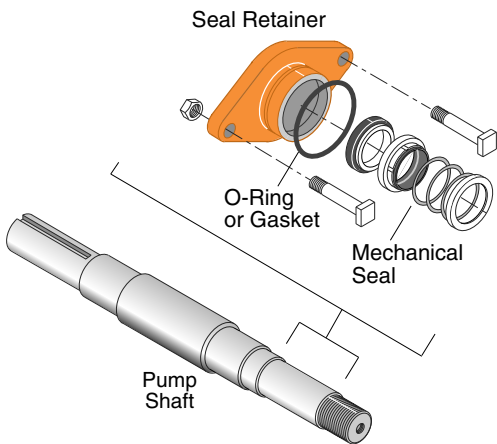

- Drawing is representative of a typical bearing frame pump, parts on some models will vary slightly.
- Frame mount pumps with a mechanical seal use the same types of components as the packing style except as shown in supplemental view.

PUMP NOMENCLATURE

S.A.E. Engine Mount

Packing / Mechanical Seal

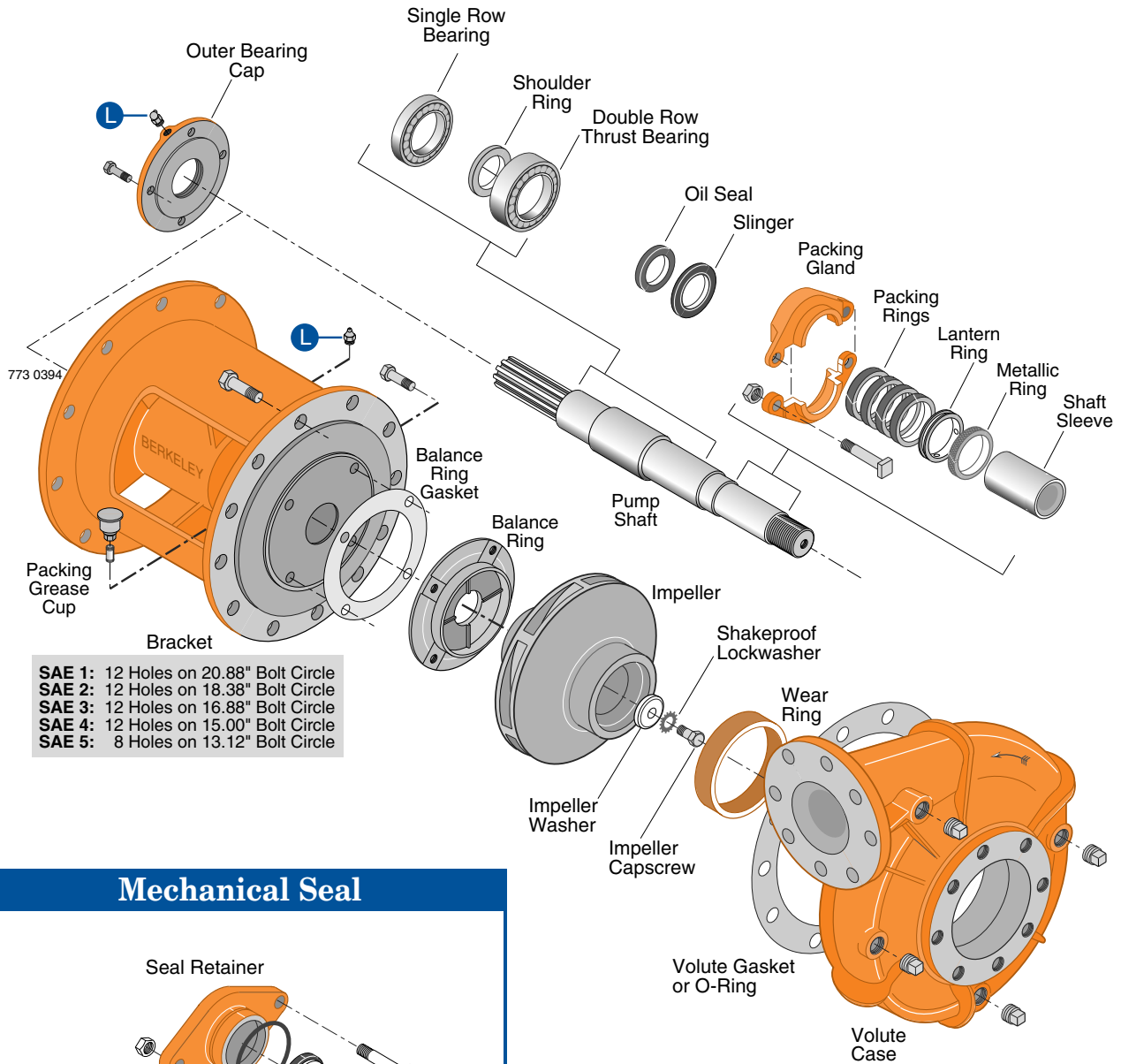

Mechanical Seal

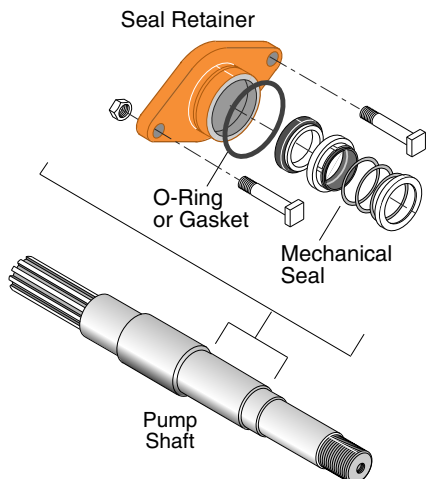

- Drawing is representative of a typical SAE engine mounted pump, parts on some models will vary slightly.
- SAE engine mounted pumps with a mechanical seal use the same types of components as the packing style except as shown in supplemental view.

PUMP NOMENCLATURE

Air Cooled Engine Drive

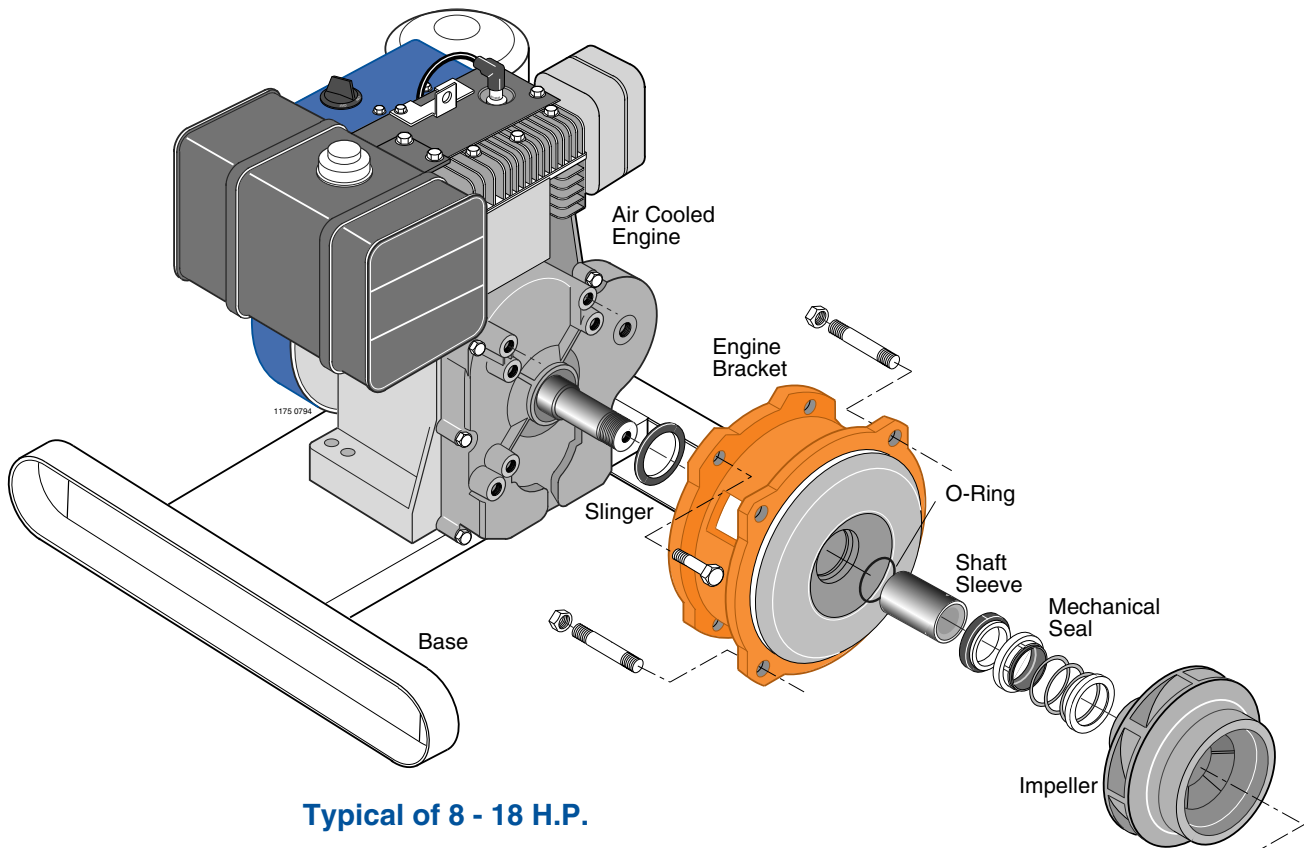

Typical of 8 - 18 H.P.

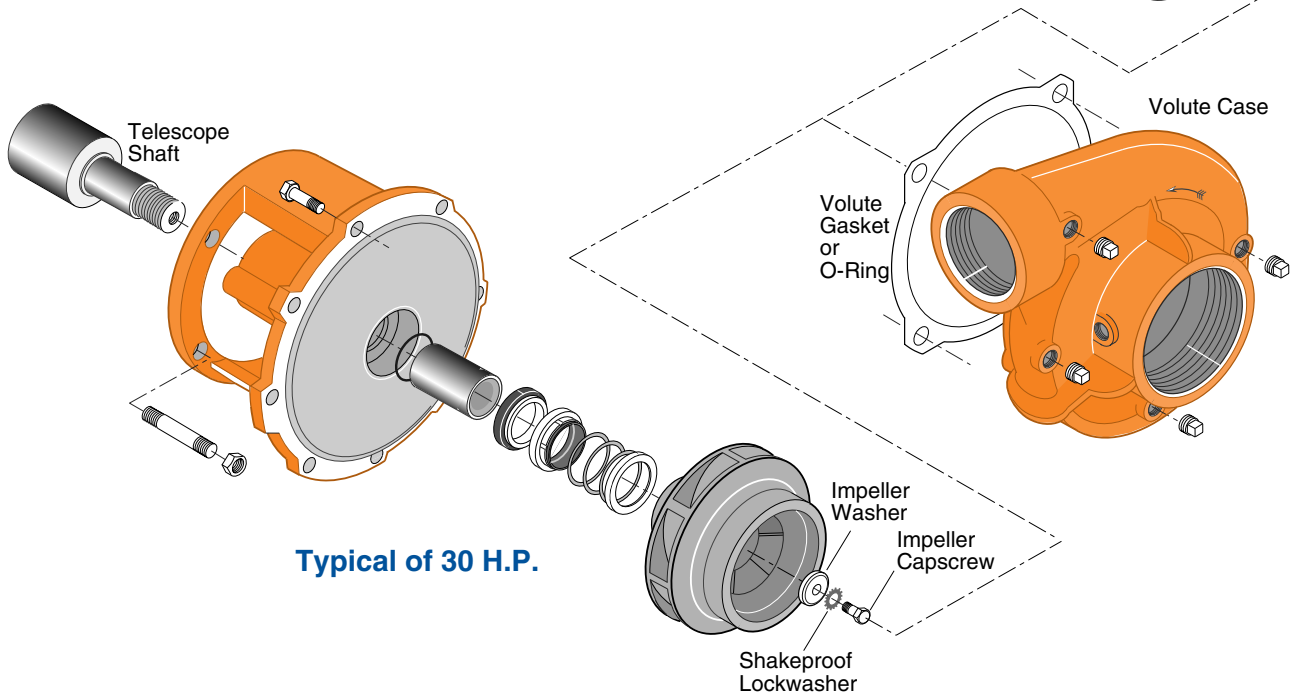

Typical of 30 H.P.

PUMP NOMENCLATURE

Air Cooled Engine Drive – Self Prime

Cast Iron

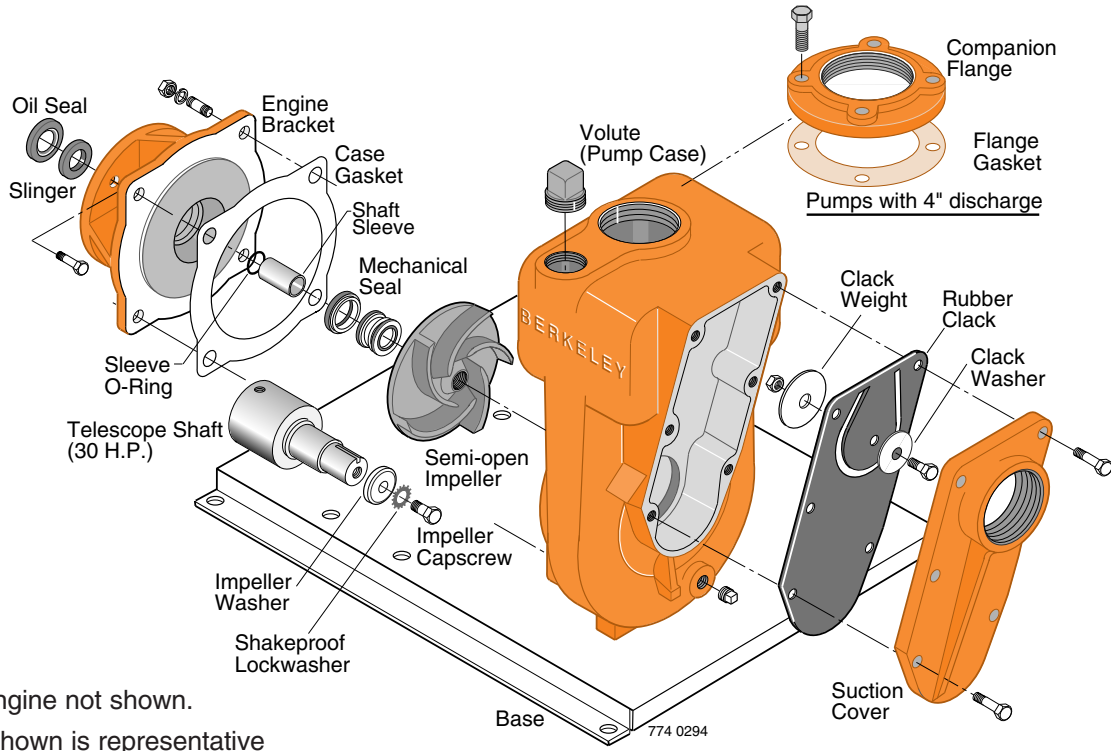

- Gas Engine not shown.
- Base shown is representative of small H.P. models.

Aluminum

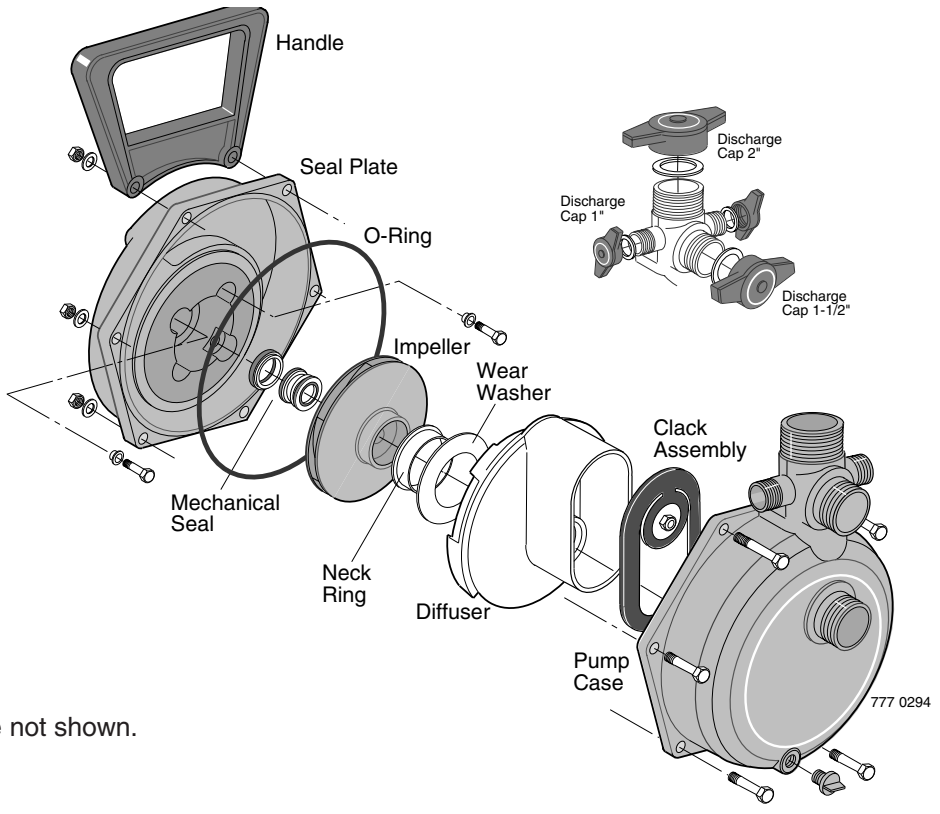

- Gas Engine not shown.